

Kennametal Kenloc LP Series & Reference Data

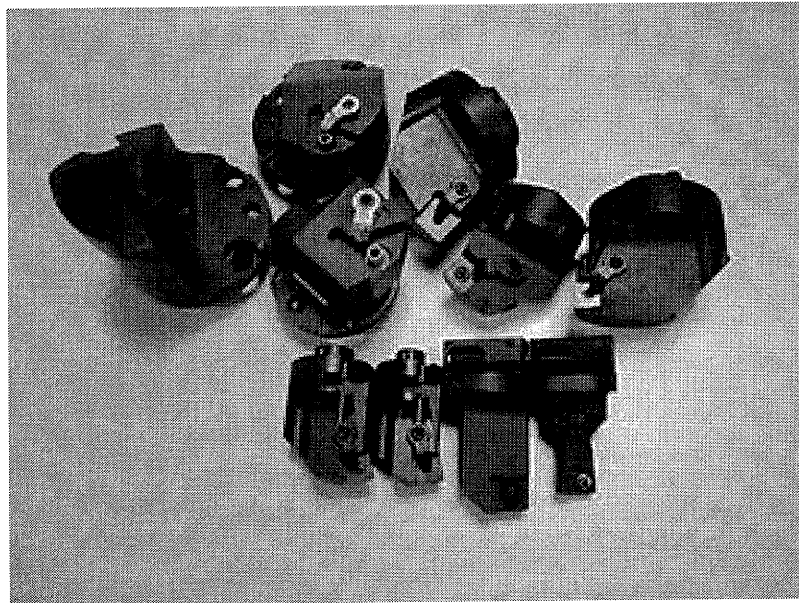

ITR
INDEXABLE TOOL REPAIR

PHONE: 262-549-9414
FAX: 262-549-9410
JEFF@ITRINCWI.COM

Kenloc Combination Toolholders

LP Series

DCH

Inserts

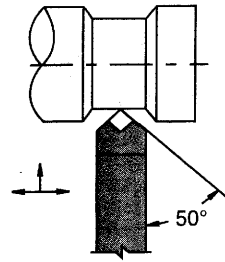

See pages 25-39
for additional insert
geometry styles.

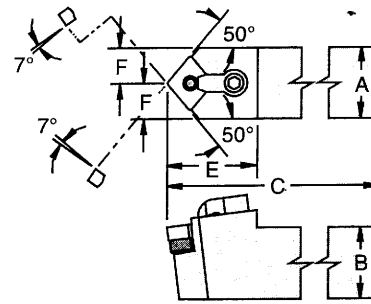

OPTIONAL
HARDWARE

Toolholders

Boring Bars & Heads

catalog number		gage insert	A	B	C	E	F	shim	lock pin	clamp	clamp screw	pin	shim
DCHNN-164C		CNMG-432	1	1	5	1 1/4	.500	SM-303	LP-56	CK-21	STC-20	RP-12	—
DCHNN-205D		CNMG-543	1 1/4	1 1/4	6	1 7/16	.625	SM-390	LP-66	CK-22	STC-20	RP-13	—
DCHNN-246D		CNMG-643	1 1/2	1 1/2	6	1.60	.750	SM-304	LP-72	CK-12	STC-4	RP-14	SM-305

Drills

DCK

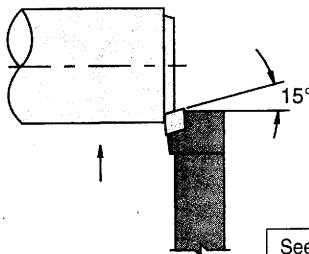

See pages 25-39
for additional insert
geometry styles.

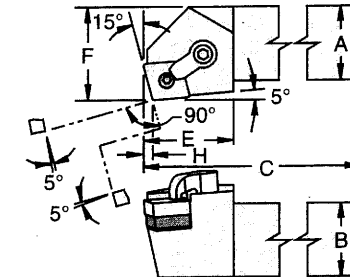

OPTIONAL
HARDWARE

Collet Chucks

Cartridges

Brazed Tools

Technical Data

Index

catalog number		gage insert	A	B	C	E	F	H	shim	lock pin	clamp	clamp screw	pin	shim
right hand	left hand													
DCKNR-124B	DCKNL-124B	CNMG-432	3/4	3/4	4 1/2	1 1/8	1.000	.122	SM-303	LP-55	CK-21	STC-20	RP-12	—
DCKNR-164C	DCKNL-164C	CNMG-432	1	1	5	1 1/8	1.250	.122	SM-303	LP-56	CK-21	STC-20	RP-12	—
DCKNR-164D	DCKNL-164D	CNMG-432	1	1	6	1 1/8	1.250	.122	SM-303	LP-56	CK-21	STC-20	RP-12	—
DCKNR-854D	DCKNL-854D	CNMG-432	1	1 1/4	6	1 1/8	1.250	.122	SM-303	LP-57	CK-21	STC-20	RP-12	—
DCKNR-204D	DCKNL-204D	CNMG-432	1 1/4	1 1/4	6	1 1/8	1.500	.122	SM-303	LP-57	CK-21	STC-20	RP-12	—
DCKNR-244D	DCKNL-244D	CNMG-432	1 1/2	1 1/2	6	1 1/8	2.000	.122	SM-303	LP-58	CK-21	STC-20	RP-12	—
DCKNR-165C	DCKNL-165C	CNMG-543	1	1	5	1 5/16	1.250	.149	SM-390	LP-65	CK-21	STC-20	RP-13	—
DCKNR-165D	DCKNL-165D	CNMG-543	1	1	6	1 5/16	1.250	.149	SM-390	LP-65	CK-21	STC-20	RP-13	—
DCKNR-855D	DCKNL-855D	CNMG-543	1	1 1/4	6	1 5/16	1.250	.149	SM-390	LP-66	CK-21	STC-20	RP-13	—
DCKNR-205D	DCKNL-205D	CNMG-543	1 1/4	1 1/4	6	1 5/16	1.500	.149	SM-390	LP-66	CK-21	STC-20	RP-13	—
DCKNR-245D	DCKNL-245D	CNMG-543	1 1/2	1 1/2	6	1 5/16	2.000	.149	SM-390	LP-67	CK-21	STC-20	RP-13	—
DCKNR-166D	DCKNL-166D	CNMG-643	1	1	6	1 3/8	1.250	.182	SM-304	LP-70	CK-12	STC-4	RP-14	SM-305
DCKNR-856D	DCKNL-856D	CNMG-643	1	1 1/4	6	1 3/8	1.250	.182	SM-304	LP-71	CK-12	STC-4	RP-14	SM-305
DCKNR-866D	DCKNL-866D	CNMG-643	1	1 1/2	6	1 3/8	1.250	.182	SM-304	LP-72	CK-12	STC-4	RP-14	SM-305
DCKNR-866E	DCKNL-866E	CNMG-643	1	1 1/2	7	1 3/8	1.250	.182	SM-304	LP-72	CK-12	STC-4	RP-14	SM-305
DCKNR-206D	DCKNL-206D	CNMG-643	1 1/4	1 1/4	6	1 3/8	1.500	.182	SM-304	LP-71	CK-12	STC-4	RP-14	SM-305
DCKNR-246D	DCKNL-246D	CNMG-643	1 1/2	1 1/2	6	1 3/8	2.000	.182	SM-304	LP-72	CK-12	STC-4	RP-14	SM-305
DCKNR-246E	DCKNL-246E	CNMG-643	1 1/2	1 1/2	7	1 3/8	2.000	.182	SM-304	LP-72	CK-12	STC-4	RP-14	SM-305
DCKNR-248E	DCKNL-248E	CNMG-866	1 1/2	1 1/2	7	1 5/8	2.000	.234	SM-319	LP-102	CK-24	STC-19	RP-15	—

Kenloc Combination Toolholders

LP Series

DCL

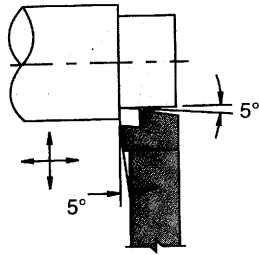

See pages 25-39
for additional insert
geometry styles.

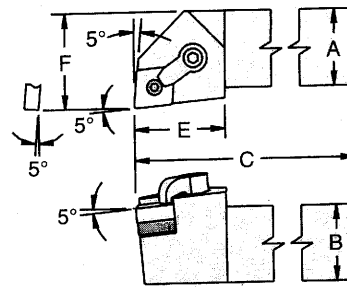

catalog number		gage insert	A	B	C	E	F	OPTIONAL HARDWARE					
right hand	left hand							shim	lock pin	clamp	clamp screw	pin	shim
DCLNR-124A	DCLNL-124A	CNMG-432	3/4	3/4	4	1 1/4	1.000	SM-303	LP-55	CK-21	STC-20	RP-12	—
DCLNR-124B	DCLNL-124B	CNMG-432	3/4	3/4	4 1/2	1 1/4	1.000	SM-303	LP-55	CK-21	STC-20	RP-12	—
DCLNR-164C	DCLNL-164C	CNMG-432	1	1	5	1 1/4	1.250	SM-303	LP-56	CK-21	STC-20	RP-12	—
DCLNR-164D	DCLNL-164D	CNMG-432	1	1	6	1 1/4	1.250	SM-303	LP-56	CK-21	STC-20	RP-12	—
DCLNR-854D	DCLNL-854D	CNMG-432	1	1 1/4	6	1 1/4	1.250	SM-303	LP-57	CK-21	STC-20	RP-12	—
DCLNR-204D	DCLNL-204D	CNMG-432	1 1/4	1 1/4	6	1 1/4	1.500	SM-303	LP-57	CK-21	STC-20	RP-12	—
DCLNR-244D	DCLNL-244D	CNMG-432	1 1/2	1 1/2	6	1 1/4	2.000	SM-303	LP-58	CK-21	STC-20	RP-12	—
DCLNR-165C	DCLNL-165C	CNMG-543	1	1	5	1 5/16	1.250	SM-390	LP-65	CK-21	STC-20	RP-13	—
DCLNR-165D	DCLNL-165D	CNMG-543	1	1	6	1 5/16	1.250	SM-390	LP-65	CK-21	STC-20	RP-13	—
DCLNR-855D	DCLNL-855D	CNMG-543	1	1 1/4	6	1 5/16	1.250	SM-390	LP-66	CK-21	STC-20	RP-13	—
—	DCLNL-205C	CNMG-543	1 1/4	1 1/4	5	1 5/16	1.500	SM-390	LP-66	CK-21	STC-20	RP-13	—
DCLNR-205D	DCLNL-205D	CNMG-543	1 1/4	1 1/4	6	1 5/16	1.500	SM-390	LP-66	CK-21	STC-20	RP-13	—
DCLNR-245D	DCLNL-245D	CNMG-543	1 1/2	1 1/2	6	1 5/16	2.000	SM-390	LP-67	CK-21	STC-20	RP-13	—
DCLNR-166C	DCLNL-166C	CNMG-643	1	1	5	1 7/16	1.250	SM-304	LP-70	CK-12	STC-4	RP-14	SM-305
DCLNR-166D	DCLNL-166D	CNMG-643	1	1	6	1 7/16	1.250	SM-304	LP-70	CK-12	STC-4	RP-14	SM-305
DCLNR-856D	DCLNL-856D	CNMG-643	1	1 1/4	6	1 1/2	1.250	SM-304	LP-71	CK-12	STC-4	RP-14	SM-305
DCLNR-866D	DCLNL-866D	CNMG-643	1	1 1/2	6	1 1/2	1.250	SM-304	LP-72	CK-12	STC-4	RP-14	SM-305
DCLNR-866E	DCLNL-866E	CNMG-643	1	1 1/2	7	1 1/2	1.250	SM-304	LP-72	CK-12	STC-4	RP-14	SM-305
DCLNR-206D	DCLNL-206D	CNMG-643	1 1/4	1 1/4	6	1 1/2	1.500	SM-304	LP-71	CK-12	STC-4	RP-14	SM-305
DCLNR-246D	DCLNL-246D	CNMG-643	1 1/2	1 1/2	6	1 1/2	2.000	SM-304	LP-72	CK-12	STC-4	RP-14	SM-305
DCLNR-246E	DCLNL-246E	CNMG-643	1 1/2	1 1/2	7	1 1/2	2.000	SM-304	LP-72	CK-12	STC-4	RP-14	SM-305
DCLNR-326F	DCLNL-326F	CNMG-643	2	2	8	1 1/2	2.500	SM-385	LP-72	CK-12	STC-4	RP-14	—
DCLNR-248E	DCLNL-248E	CNMG-866	1 1/2	1 1/2	7	1 9/16	2.000	SM-319	LP-102	CK-24	STC-19	RP-15	—
DCLNR-328	DCLNL-328	CNMG-866	2	2	18	1 9/16	2.500	SM-319	LP-103	CK-24	STC-19	RP-15	—

550-9 \$91/ea

-82

8.21

Inserts

Toolholders

Boring Bars & Heads

Drills

Collet Chucks

Cartridges

Brazed Tools

Technical Data

Index

Kenloc Combination Toolholders

LP Series

DDJ

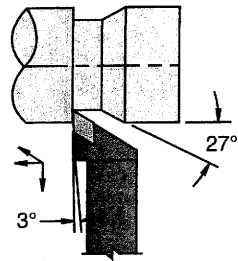

See pages 38-49
for additional insert
geometry styles.

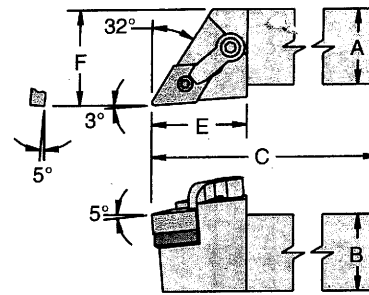

OPTIONAL HARDWARE

catalog number		gage insert	A	B	C	E	F	OPTIONAL HARDWARE					
right hand	left hand							shim	lock pin	clamp	clamp screw	pin	shim
DDJNR-124A	DDJNL-124A	DNMG-432	3/4	3/4	4	1 3/8	1.000	SM-306	LP-55	CK-22	STC-20	RP-12	SM-442
DDJNR-124B	DDJNL-124B	DNMG-432	3/4	3/4	4 1/2	1 3/8	1.000	SM-306	LP-55	CK-22	STC-20	RP-12	SM-442
DDJNR-164C	DDJNL-164C	DNMG-432	1	1	5	1 1/4	1.250	SM-306	LP-56	CK-22	STC-20	RP-12	SM-442
DDJNR-164D	DDJNL-164D	DNMG-432	1	1	6	1 1/4	1.250	SM-306	LP-56	CK-22	STC-20	RP-12	SM-442
DDJNR-854D	DDJNL-854D	DNMG-432	1	1 1/4	6	1 1/4	1.250	SM-306	LP-57	CK-22	STC-20	RP-12	SM-442
DDJNR-204D	DDJNL-204D	DNMG-432	1 1/4	1 1/4	6	1 1/4	1.500	SM-306	LP-57	CK-22	STC-20	RP-12	SM-442
DDJNR-165D	DDJNL-165D	DNMG-543	1	1	6	1 3/8	1.250	SM-307	LP-65	CK-12	STC-4	RP-13	SM-308
DDJNR-855D	DDJNL-855D	DNMG-543	1	1 1/4	6	1 3/8	1.250	SM-307	LP-66	CK-12	STC-4	RP-13	SM-308
DDJNR-865D	DDJNL-865D	DNMG-543	1	1 1/2	6	1 3/8	1.250	SM-307	LP-67	CK-12	STC-4	RP-13	SM-308
DDJNR-865E	DDJNL-865E	DNMG-543	1	1 1/2	7	1 3/8	1.250	SM-307	LP-67	CK-12	STC-4	RP-13	SM-308
DDJNR-205D	DDJNL-205C	DNMG-543	1 1/4	1 1/4	5	1 3/8	1.500	SM-307	LP-66	CK-12	STC-4	RP-13	SM-308
DDJNR-205D	DDJNL-205D	DNMG-543	1 1/4	1 1/4	6	1 3/8	1.500	SM-307	LP-66	CK-12	STC-4	RP-13	SM-308
DDJNR-245D	DDJNL-245D	DNMG-543	1 1/2	1 1/2	6	1 3/8	2.000	SM-307	LP-67	CK-12	STC-4	RP-13	SM-308
DDJNR-245E	DDJNL-245E	DNMG-543	1 1/2	1 1/2	7	1 3/8	2.000	SM-307	LP-67	CK-12	STC-4	RP-13	SM-308
DDJNR-325F	DDJNL-325F	DNMG-543	2	2	8	1 3/8	2.500	SM-307	LP-67	CK-12	STC-4	RP-13	SM-308

DDP

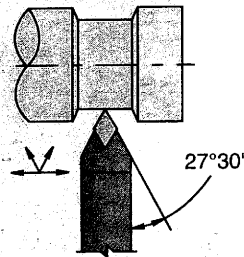

See pages 38-49
for additional insert
geometry styles.

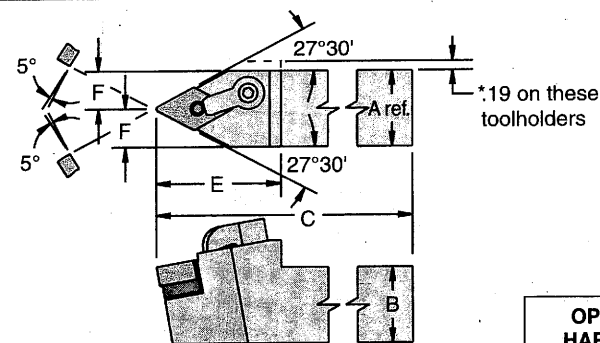

OPTIONAL HARDWARE

catalog number		gage insert	A	B	C	E	F	OPTIONAL HARDWARE					
right hand	left hand							shim	lock pin	clamp	clamp screw	pin	shim
DDPNN-164D		DNMG-432	1	1	6	1 5/8	.500	SM-306	LP-56	CK-22	STC-20	RP-12	SM-442
DDPNN-855D*		DNMG-543	1	1 1/4	6	1 5/8	.500	SM-307	LP-66	CK-12	STC-4	RP-13	SM-308
DDPNN-865E*		DNMG-543	1	1 1/2	7	1 5/8	.500	SM-307	LP-67	CK-12	STC-4	RP-13	SM-308
DDPNN-245D		DNMG-543	1 1/2	1 1/2	6	1 5/8	.750	SM-307	LP-67	CK-12	STC-4	RP-13	SM-308

Inserts

Toolholders

Boring Bars & Heads

Drills

Collet Chucks

Cartridges

Brazed Tools

Technical Data

Index

LP Series

DDQ

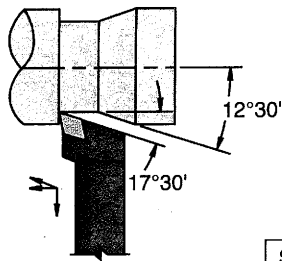

See pages 38-49
for additional insert
geometry styles.

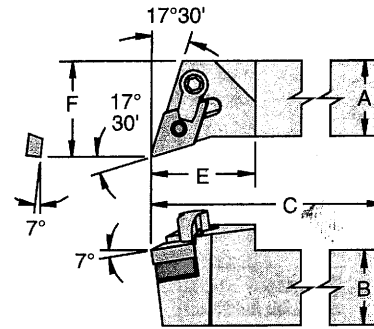

catalog number		gage insert	A	B	C	E	F	OPTIONAL HARDWARE					
right hand	left hand							shim	lock pin	clamp	clamp screw	pin	shim
DDQNR-124B	DDQNL-124B	DNMG-432	3/4	3/4	4 1/2	1 3/8	1.000	SM-306	LP-55	CK-22	STC-20	RP-12	SM-442
DDQNR-164C	DDQNL-164C	DNMG-432	1	1	5	1 3/8	1.250	SM-306	LP-56	CK-22	STC-20	RP-12	SM-442
DDQNR-164D	DDQNL-164D	DNMG-432	1	1	6	1 3/8	1.250	SM-306	LP-56	CK-22	STC-20	RP-12	SM-442
DDQNR-204D	DDQNL-204D	DNMG-432	1 1/4	1 1/4	6	1 3/8	1.500	SM-306	LP-57	CK-22	STC-20	RP-12	SM-442
DDQNR-165C	DDQNL-165C	DNMG-543	1	1	5	1 15/32	1.250	SM-307	LP-65	CK-12	STC-4	RP-13	SM-308
DDQNR-165D	DDQNL-165D	DNMG-543	1	1	6	1 15/32	1.250	SM-307	LP-65	CK-12	STC-4	RP-13	SM-308
DDQNR-205D	DDQNL-205D	DNMG-543	1 1/4	1 1/4	6	1 15/32	1.500	SM-307	LP-66	CK-12	STC-4	RP-13	SM-308
DDQNR-245D	DDQNL-245D	DNMG-543	1 1/2	1 1/2	6	1 15/32	2.000	SM-307	LP-67	CK-12	STC-4	RP-13	SM-308
DDQNR-245E	DDQNL-245E	DNMG-543	1 1/2	1 1/2	7	1 15/32	2.000	SM-307	LP-67	CK-12	STC-4	RP-13	SM-308

DRG

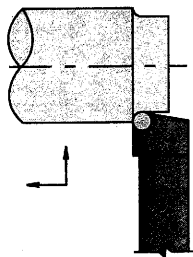

See pages 50-51
for additional insert
geometry styles.

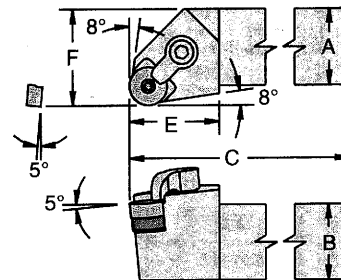

catalog number		gage insert	A	B	C	E	F	OPTIONAL HARDWARE					
right hand	left hand							shim	lock pin	clamp	clamp screw	pin	shim
DRGNR-123B	DRGNL-123B	RNMG-32	3/4	3/4	4 1/2	1 1/8	1.000	SM-311	LP-31	CK-6	STC-5	RP-11	—
DRGNR-163D	DRGNL-163D	RNMG-32	1	1	6	1 1/8	1.250	SM-311	LP-31	CK-6	STC-5	RP-11	—
DRGNR-124B	DRGNL-124B	RNMG-43	3/4	3/4	4 1/2	1 1/4	1.000	SM-312	LP-55	CK-21	STC-20	RP-12	SM-413
DRGNR-164C	DRGNL-164C	RNMG-43	1	1	5	1 1/4	1.250	SM-312	LP-56	CK-21	STC-20	RP-12	SM-413
DRGNR-164D	DRGNL-164D	RNMG-43	1	1	6	1 1/4	1.250	SM-312	LP-56	CK-21	STC-20	RP-12	SM-413
DRGNR-854D	DRGNL-854D	RNMG-43	1	1 1/4	6	1 1/4	1.250	SM-312	LP-57	CK-21	STC-20	RP-12	SM-413
DRGNR-864D	DRGNL-864D	RNMG-43	1	1 1/2	6	1 1/4	1.250	SM-312	LP-58	CK-21	STC-20	RP-12	SM-413
DRGNR-204D	DRGNL-204D	RNMG-43	1 1/4	1 1/4	6	1 1/4	1.500	SM-312	LP-57	CK-21	STC-20	RP-12	SM-413
DRGNR-165D	DRGNL-165D	RNMG-54	1	1	6	1 1/4	1.250	SM-313	LP-65	CK-21	STC-20	RP-13	—
DRGNR-855D	DRGNL-855D	RNMG-54	1	1 1/4	6	1 1/4	1.250	SM-313	LP-66	CK-21	STC-20	RP-13	—
DRGNR-205D	DRGNL-205D	RNMG-54	1 1/4	1 1/4	6	1 1/4	1.500	SM-313	LP-66	CK-21	STC-20	RP-13	—
DRGNR-166D	DRGNL-166D	RNMG-64	1	1	6	1 3/8	1.250	SM-314	LP-70	CK-12	STC-4	RP-14	—
DRGNR-866E	DRGNL-866E	RNMG-64	1	1 1/2	7	1 3/8	1.250	SM-314	LP-72	CK-12	STC-4	RP-14	—
DRGNR-206D	DRGNL-206D	RNMG-64	1 1/4	1 1/4	6	1 3/8	1.500	SM-314	LP-71	CK-12	STC-4	RP-14	—
DRGNR-246D	DRGNL-246D	RNMG-64	1 1/2	1 1/2	6	1 3/8	2.000	SM-314	LP-72	CK-12	STC-4	RP-14	—
DRGNR-248E	DRGNL-248E	RNMG-86	1 1/2	1 1/2	7	1 5/8	2.000	SM-315	LP-102	CK-24	STC-19	RP-15	—

Steel Shank Boring Bars

Kenloc Combination – LP Series with Through Coolant

A-DCF

Inserts

Toolholders

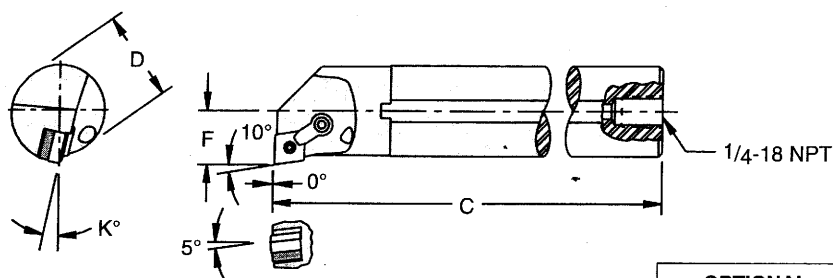
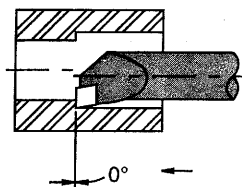

See pages 24-39
for additional insert
geometry styles.

OPTIONAL
HARDWARE

catalog number		gage insert	D	C	F	K°	min. bore	OPTIONAL HARDWARE					
right hand	left hand							shim	lock pin	clamp	clamp screw	shim	pin
A16-DCFNR4	A16-DCFNL4	CNMG-432	1	12	.625	14°	1.205	—	LP-59	CK-7	STC-9	—	—
A20-DCFNR4	A20-DCFNL4	CNMG-432	1 1/4	14	.765	14°	1.470	SM-303	LP-53	CK-21	STC-20	—	RP-12
A24-DCFNR4	A24-DCFNL4	CNMG-432	1 1/2	14	.890	12°	1.760	SM-303	LP-53	CK-21	STC-20	—	RP-12
A24-DCFNR5	A24-DCFNL5	CNMG-543	1 1/2	14	.890	14°	1.760	SM-390	LP-68	CK-21	STC-20	—	RP-13
A32-DCFNR5	A32-DCFNL5	CNMG-543	2	16	1.281	12°	2.400	SM-390	LP-68	CK-21	STC-20	—	RP-13
A32-DCFNR6	A32-DCFNL6	CNMG-643	2	16	1.281	12°	2.400	SM-304	LP-70	CK-12	STC-4	—	RP-14
A40-DCFNR6	A40-DCFNL6	CNMG-643	2 1/2	16	1.531	10°	3.030	SM-304	LP-70	CK-12	STC-4	—	RP-14

Boring Bars & Heads

Drills

A-DCK

Collet Chucks

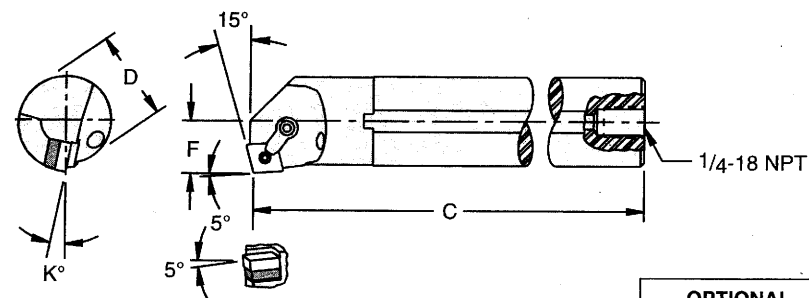
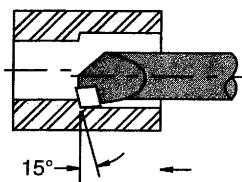

See pages 24-39
for additional insert
geometry styles.

OPTIONAL
HARDWARE

catalog number		gage insert	D	C	F	K°	min. bore	OPTIONAL HARDWARE					
right hand	left hand							shim	lock pin	clamp	clamp screw	shim	pin
A20-DCKNR4	A20-DCKNL4	CNMG-432	1 1/4	14	.765	14°	1.470	SM-303	LP-53	CK-21	STC-20	—	RP-12
A24-DCKNR4	A24-DCKNL4	CNMG-432	1 1/2	14	.890	12°	1.760	SM-303	LP-53	CK-21	STC-20	—	RP-12
A32-DCKNR4	A32-DCKNL4	CNMG-432	2	16	1.281	12°	2.400	SM-303	LP-55	CK-21	STC-20	—	RP-12
A32-DCKNR5	A32-DCKNL5	CNMG-543	2	16	1.281	12°	2.400	SM-390	LP-68	CK-21	STC-20	—	RP-13
A40-DCKNR5	A40-DCKNL5	CNMG-543	2 1/2	16	1.531	10°	3.030	SM-390	LP-68	CK-21	STC-20	—	RP-13
A40-DCKNR6	A40-DCKNL6	CNMG-643	2 1/2	16	1.531	10°	3.030	SM-304	LP-70	CK-12	STC-4	—	RP-14

Brazed Tools

Technical Data

Index

Kenloc Combination – LP Series with Through Coolant

A-DCL

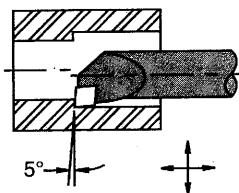

See pages 24-39
for additional insert
geometry styles.

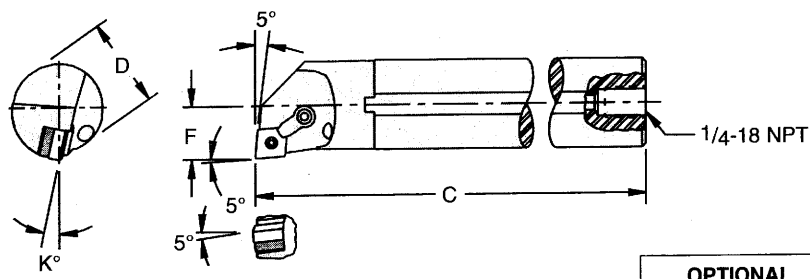

catalog number		gage insert	D	C	F	K°	min. bore	OPTIONAL HARDWARE					
right hand	left hand							shim	lock pin	clamp	clamp screw	shim	pin
A16-DCLNR4	A16-DCLNL4	CNMG-432	1	12	.625	14°	1.205	—	LP-59	CK-7	STC-9	—	—
A20-DCLNR4	A20-DCLNL4	CNMG-432	1 1/4	14	.765	14°	1.470	SM-303	LP-53	CK-21	STC-20	—	RP-12
A24-DCLNR4	A24-DCLNL4	CNMG-432	1 1/2	14	.890	14°	1.760	SM-303	LP-53	CK-21	STC-20	—	RP-12
A28-DCLNR4	A28-DCLNL4	CNMG-432	1 3/4	14	1.015	12°	2.010	SM-303	LP-55	CK-21	STC-20	—	RP-12
A32-DCLNR4	A32-DCLNL4	CNMG-432	2	16	1.281	10°	2.400	SM-303	LP-55	CK-21	STC-20	—	RP-12
A40-DCLNR4	A40-DCLNL4	CNMG-432	2 1/2	16	1.531	8°	3.030	SM-303	LP-55	CK-21	STC-20	—	RP-12
A24-DCLNR5	A24-DCLNL5	CNMG-543	1 1/2	14	.890	14°	1.760	SM-390	LP-68	CK-22	STC-20	—	RP-13
A32-DCLNR5	A32-DCLNL5	CNMG-543	2	16	1.281	12°	2.400	SM-390	LP-68	CK-22	STC-20	—	RP-13
A40-DCLNR5	A40-DCLNL5	CNMG-543	2 1/2	16	1.531	10°	3.030	SM-390	LP-65	CK-22	STC-20	—	RP-13
A32-DCLNR6	A32-DCLNL6	CNMG-643	2	16	1.281	12°	2.400	SM-304	LP-70	CK-12	STC-4	—	RP-14
A36-DCLNR6	A36-DCLNL6	CNMG-643	2 1/4	16	1.406	10°	2.650	SM-304	LP-70	CK-12	STC-4	—	RP-14
A40-DCLNR6	A40-DCLNL6	CNMG-643	2 1/2	16	1.531	10°	3.030	SM-304	LP-70	CK-12	STC-4	—	RP-14

A-DDP

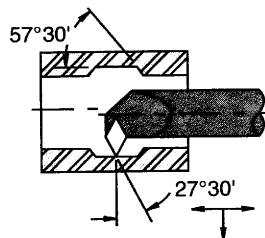

See pages 38-49
for additional insert
geometry styles.

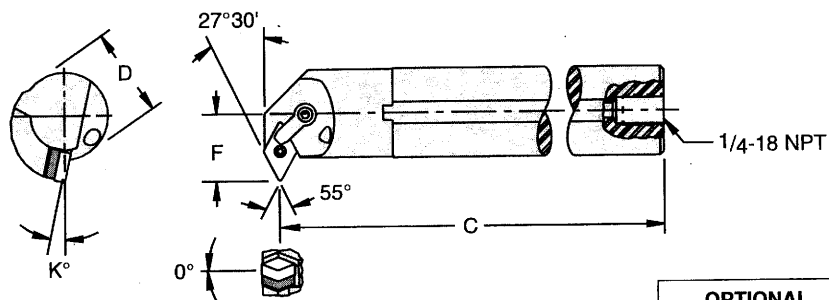

catalog number		gage insert	D	C	F	K°	min. bore	OPTIONAL HARDWARE					
right hand	left hand							shim	lock pin	clamp	clamp screw	shim	pin
A20-DDPNR4	A20-DDPNL4	DNMG-432	1 1/4	14	1.000	13°	1.705	SM-306	LP-55	CK-22	STC-20	—	RP-12
A24-DDPNR4	A24-DDPNL4	DNMG-432	1 1/2	14	1.125	12°	2.000	SM-306	LP-55	CK-22	STC-20	—	RP-12

Inserts
 Toolholders
 Boring Bars & Heads
 Drills
 Collet Chucks
 Cartridges
 Brazed Tools
 Technical Data
 Index

Steel Shank Boring Bars

Kenloc Combination – LP Series with Through Coolant

A-DDQ

Inserts

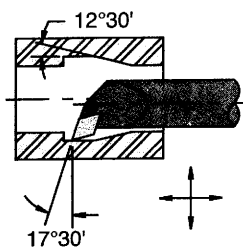

Toolholders

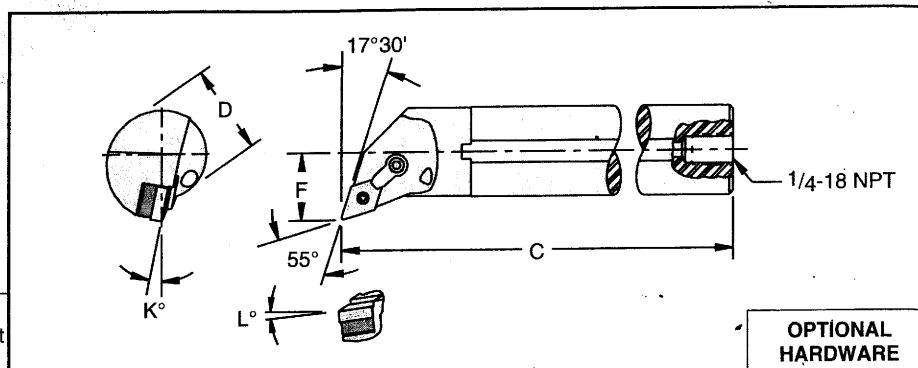

See pages 38-49
for additional insert
geometry styles.

OPTIONAL
HARDWARE

Boring Bars & Heads

catalog number		gage insert	D	C	F	K°	L°	min. bore	shim	lock pin	clamp	clamp screw	OPTIONAL HARDWARE	
right hand	left hand												shim	pin
A20-DDQNR4	A20-DDQNL4	DNMG-432	1 1/4	14	1.000	12°	10°	1.705	SM-306	LP-53	CK-22	STC-20	—	RP-12
A24-DDQNR4	A24-DDQNL4	DNMG-432	1 1/2	14	1.125	8° 30'	8° 30'	2.000	SM-306	LP-55	CK-22	STC-20	—	RP-12

A-DDU

Drills

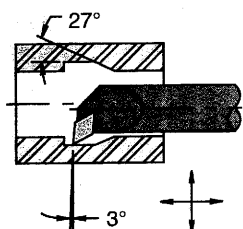

Collet Chucks

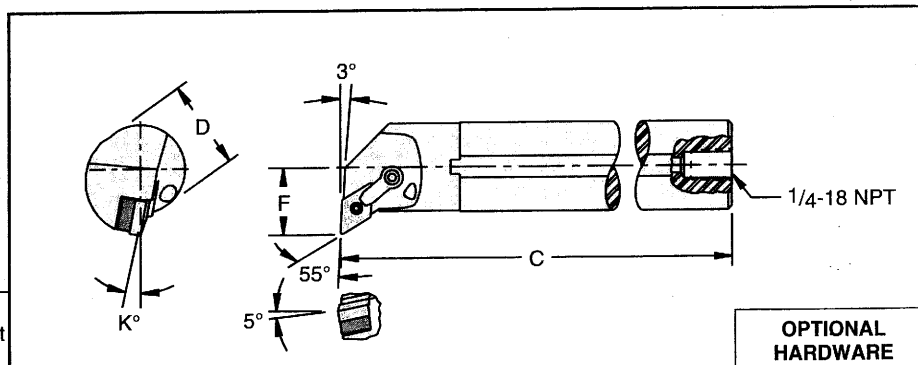

See pages 38-49
for additional insert
geometry styles.

OPTIONAL
HARDWARE

Cartridges

catalog number		gage insert	D	C	F	K°	min. bore	shim	lock pin	clamp	clamp screw	OPTIONAL HARDWARE	
right hand	left hand											shim	pin
A20-DDUNR4	A20-DDUNL4	DNMG-432	1 1/4	14	1.000	10°	1.705	SM-306	LP-55	CK-22	STC-20	—	RP-12
A24-DDUNR4	A24-DDUNL4	DNMG-432	1 1/2	14	1.125	10°	2.000	SM-306	LP-55	CK-22	STC-20	—	RP-12
A28-DDUNR4	A28-DDUNL4	DNMG-432	1 3/4	14	1.250	10°	2.250	SM-306	LP-55	CK-22	STC-20	—	RP-12
A32-DDUNR4	A32-DDUNL4	DNMG-432	2	16	1.375	10°	2.500	SM-306	LP-55	CK-22	STC-20	—	RP-12

Brazed Tools

Technical Data

Index

Kenloc Combination – LP Series with Through Coolant

A-DSK

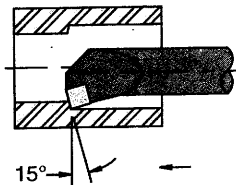

See pages 50-63
for additional insert
geometry styles.

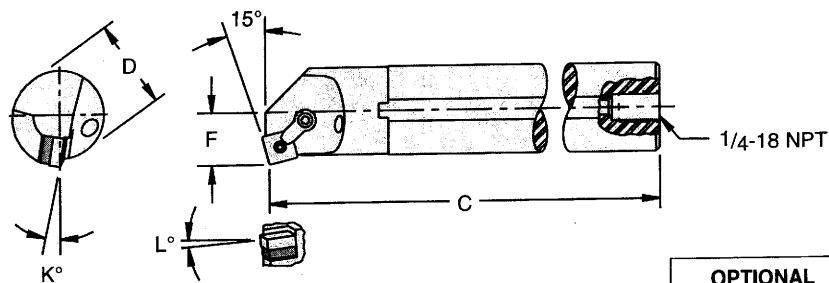

catalog number		gage insert	D	C	F	K°	L	min. bore	OPTIONAL HARDWARE					
right hand	left hand								shim	lock pin	clamp	clamp screw	shim	pin
A20-DSKNR4	A20-DSKNL4	SNMG-432	1 1/4	14	.765	14°	5°	1.470	SM-297	LP-53	CK-21	STC-20	—	RP-12
A24-DSKNR4	A24-DSKNL4	SNMG-432	1 1/2	14	.890	10°	6°	1.760	SM-297	LP-53	CK-21	STC-20	—	RP-12
A28-DSKNR4	A28-DSKNL4	SNMG-432	1 3/4	14	1.015	10°	6°	2.010	SM-297	LP-53	CK-21	STC-20	—	RP-12
A32-DSKNR6	A32-DSKNL6	SNMG-643	2	16	1.281	12°	5°	2.400	SM-299	LP-70	CK-12	STC-4	—	RP-14
A36-DSKNR6	—	SNMG-643	2 1/4	16	1.406	10°	6°	2.650	SM-299	LP-70	CK-12	STC-4	—	RP-14
A40-DSKNR6	A40-DSKNL6	SNMG-643	2 1/2	16	1.531	10°	6°	3.030	SM-299	LP-70	CK-12	STC-4	—	RP-14

A-DTF

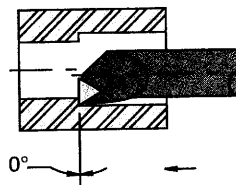

See pages 62-75
for additional insert
geometry styles.

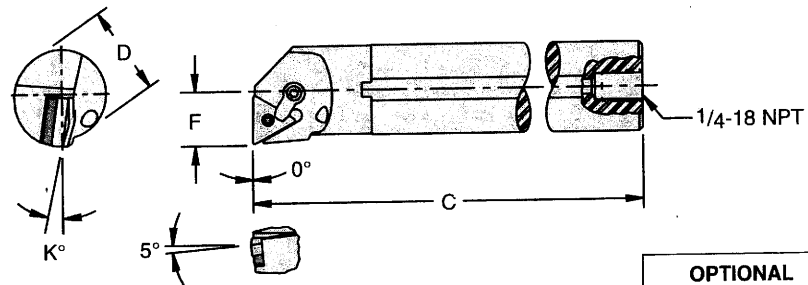

catalog number		gage insert	D	C	F	K°	min. bore	OPTIONAL HARDWARE					
right hand	left hand							shim	lock pin	clamp	clamp screw	shim	pin
A16-DTFNR3	A16-DTFNL3	TNMG-332	1	12	.640	12°	1.200	SM-290	LP-30	CK-20	STC-11	—	RP-11
A20-DTFNR3	A20-DTFNL3	TNMG-332	1 1/4	14	.765	10°	1.470	SM-290	LP-30	CK-21	STC-20	—	RP-11
A24-DTFNR3	A24-DTFNL3	TNMG-332	1 1/2	14	.890	10°	1.760	SM-290	LP-31	CK-21	STC-20	—	RP-11
A28-DTFNR3	A28-DTFNL3	TNMG-332	1 3/4	14	1.015	10°	2.010	SM-290	LP-31	CK-21	STC-20	—	RP-11
A32-DTFNR4	A32-DTFNL4	TNMG-433	2	16	1.281	8°	2.400	SM-292	LP-55	CK-9	STC-4	—	RP-12
A36-DTFNR4	—	TNMG-433	2 1/4	16	1.406	8°	2.650	SM-292	LP-56	CK-9	STC-4	—	RP-12
A40-DTFNR4	A40-DTFNL4	TNMG-433	2 1/2	16	1.531	8°	3.030	SM-292	LP-56	CK-9	STC-4	—	RP-12

Technical Data

Hardware

Kenloc Toolholders and Boring Bars with LP Lock Pins

These charts list the effective width of the chipbreaker land when using a standard chipbreaker plate in a Kenloc combination tool, a negative rake Kendex tool and a positive rake Kendex tool.

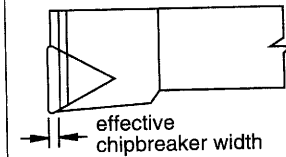
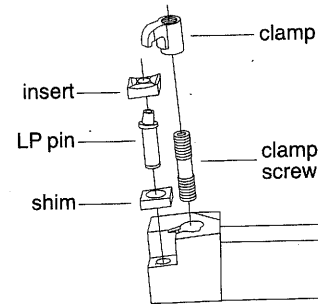

insert size and style	insert thickness	shim	shim retaining pin	LP lock pin	clamp	clamp screw	chip-breaker	effective width
diamond 1/2 80°	3/16	SM-303	RP-12	LP-55 (3/4) LP-56 (1) LP-57 (1 1/4) LP-58 (1 1/2)	CK-21	STC-20	CBD-16C* CBD-16N CBD-16F	.077 .115 .077
5/8 80°	1/4	SM-390	RP-13	LP-65 (1) LP-66 (1 1/4)	CK-21	STC-20	CBD-5C* CBD-5N	.140 .115
3/4 80°	1/4 3/16	SM-304 SM-305 SM-385	RP-14	LP-70 (1) LP-71 (1 1/4) LP-72 (1 1/2)	CK-12	STC-4	CBD-6C* CBD-6N CBD-6F	.140 .115 .077
1 80°	3/8	SM-319	RP-15	LP-102 (1 1/2)	CK-24	STC-19	CBD-8C* CBD-8N	.140 .115
diamond 1/2 55°	3/16	SM-306	RP-12	LP-55 (3/4) LP-56 (1) LP-57 (1 1/4) LP-58 (1 1/2)	CK-22	STC-20	CBL-6 (R)** CBL-7 (L)**	.090 .090
5/8 55°	1/4 3/16	SM-307 SM-308	RP-13	LP-65 (1) LP-66 (1 1/4) LP-67 (1 1/2)	CK-12	STC-4	CBL-12 (R)** CBL-13 (L)**	.115 .115
round 3/8	1/8	SM-311	RP-11	LP-31 (3/4) LP-32	CK-6	STC-5	CBR-12	.065
1/2	1/8 3/16	SM-413 SM-312	RP-12	LP-55 (3/4) LP-56 (1) LP-57 (1 1/4) LP-58 (1 1/2)	CK-21	STC-20	CBR-16	.070
5/8	1/4	SM-313	RP-13	LP-65 (1) LP-66 (1 1/4) LP-67 (1 1/2)	CK-21	STC-20	CBR-20	.077
3/4	1/4	SM-314	RP-14	LP-70 (1) LP-71 (1 1/4) LP-72 (1 1/2)	CK-12	STC-4	CBR-24	.085
1	3/8	SM-315	RP-15	LP-102 (1 1/2)	CK-24	STC-19	CBR-32	.100

*Use with 100° diamond insert only.

**"R" is right-handed for a side cutting tool and left-handed for an end cutting tool. "L" is left-handed for a side cutting tool and right-handed for an end cutting tool.

Inserts

Toolholders

Boring Bars & Heads

Drills

Collet Chucks

Cartridges

Brazed Tools

Technical Data









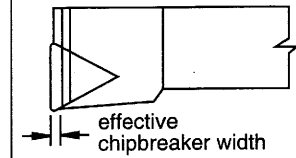
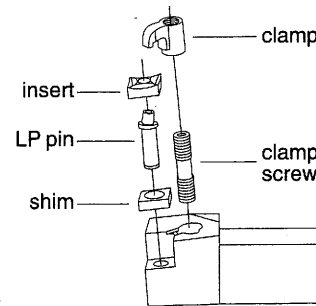

Index

Hardware

Kenloc Toolholders and Boring Bars with LP Lock Pins (Cont'd)

These charts list the effective width of the chipbreaker land when using a standard chipbreaker plate in a Kenloc combination tool, a negative rake Kendex tool and a positive rake Kendex tool.



insert size and style	insert thickness	shim	shim retaining pin	LP lock pin	clamp	clamp screw	chip-breaker	effective width
square 3/8 	1/8	SM-296	RP-11	LP-31 (3/4) LP-32	CK-6	STC-5	CBS-12	.078
1/2 	3/16	SM-297	RP-12	LP-55 (3/4) LP-56 (1) LP-57 (1 1/4) LP-58 (1 1/2)	CK-21	STC-20	CBS-16 CBS-16N CBS-16F	.172 .115 .078
5/8 	1/4	SM-298	RP-13	LP-65 (1) LP-66 (1 1/4) LP-67 (1 1/2)	CK-21	STC-20	CBS-20	.171
3/4 	1/4 3/16	SM-299 SM-300	RP-14	LP-70 (1) LP-71 (1 1/4) LP-72 (1 1/2)	CK-12	STC-4	CBS-24 CBS-24N CBS-24F	.203 .115 .078
1 	3/8	SM-301	RP-15	LP-102 (1 1/2) LP-103 (2)	CK-24	STC-19	CBS-32	.188
triangle 3/8 	1/8 3/16	SM-291 SM-290	RP-11	LP-31 (3/4) LP-32	CK-21	STC-20	CBT-12/T33AG† CBT-12N/T33AD† CBT-12F/T33AC†	.159 .110 .087
1/2 	3/16	SM-292	RP-12	LP-55 (3/4) LP-56 (1) LP-57 (1 1/4) LP-58 (1 1/2)	CK-9 CK-12	STC-4	CBT-16 CBT-16N CBT-16F	.220 .130 .084
5/8 	1/4	SM-293	RP-13	LP-65 (1) LP-66 (1 1/4) LP-67 (1 1/2)	CK-24	STC-19	CBT-20 CBT-20N	.220 .130
3/4 	3/8	SM-294	RP-14	LP-73 (1 1/2)	CK-24	STC-19	CBT-24	.280
diamond 3/8  35°	3/16	SM-310	RP-11	LP-31 (3/4) LP-32 (1)	CK-22	STC-20	CBL-10 (R)** CBL-11 (L)**	.078 .078
1/2  35°	3/16	SM-386	RP-12	LP-56 (1) LP-57 (1 1/4) LP-58 (1 1/2)	CK-26	STC-4	CBL-16 (R)** CBL-17 (L)**	.115 .115

*Use with 100° diamond insert only.

**"R" is right-handed for a side cutting tool and left-handed for an end cutting tool. "L" is left-handed for a side cutting tool and right-handed for an end cutting tool.

†CBT-12, 12N and 12F are .062" thick. T33AG, AD and AC are .094" thick.

Inserts

Toolholders

Boring Bars & Heads

Drills

Collet Chucks

Cartridges

Brazed Tools

Technical Data

Index

Technical Data

Hardware (Lock Pins)

KL Lock Pins

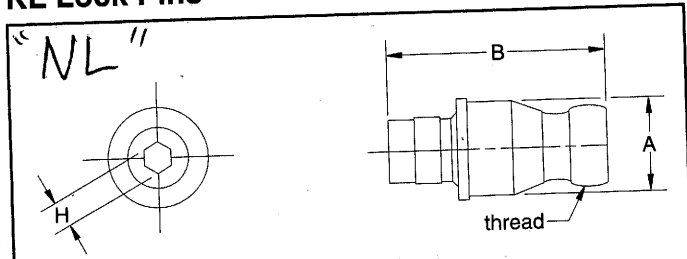

catalog number	A	B	H	threads
KL-23	.188	.322	1/16	8-32
KL-33	.219	.347	5/64	10-32
KL-33L	.219	.410	5/64	10-32
KL-34	.219	.452	5/64	10-32
KL-34L	.219	.513	5/64	10-32
KL-44	.281	.519	3/32	1/4-28
KL-46	.281	.676	3/32	1/4-28
KL-46L	.281	.733	3/32	1/4-28
KL-58	.373	.857	1/8	5/16-24
KL-68	.435	.857	9/64	3/8-24
KL-68L	.435	.948	9/64	3/8-24
KL-810	.560	1.168	5/32	7/16-20

LP Lock Pins

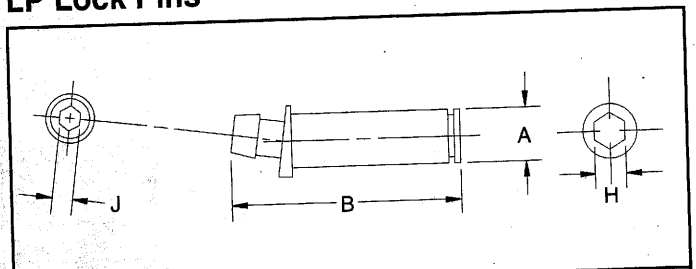

catalog number	A	B	H	J
LP-30	.1860	.530	3/32	3/64
LP-31	.1860	.595	3/32	3/64
LP-32	.1860	.970	3/32	3/64
LP-53	.227	.633	1/8	3/32
LP-55	.227	.713	1/8	3/32
LP-56	.227	.963	1/8	3/32
LP-57	.225	1.213	1/8	3/32
LP-58	.225	1.463	1/8	3/32
LP-59	.186	.446	3/32	3/32
LP-65	.269	.970	5/32	7/64
LP-66	.269	1.220	5/32	7/64
LP-67	.269	1.470	5/32	7/64
LP-68	.269	.720	5/32	7/64
LP-70	.299	.970	5/32	5/32
LP-71	.299	1.220	5/32	5/32
LP-72	.299	1.470	5/32	5/32
LP-73	.299	1.470	5/32	5/32
LP-102	.320	1.470	5/32	5/32
LP-103	.320	1.970	5/32	5/32

KLM (Metric) Lock Pins

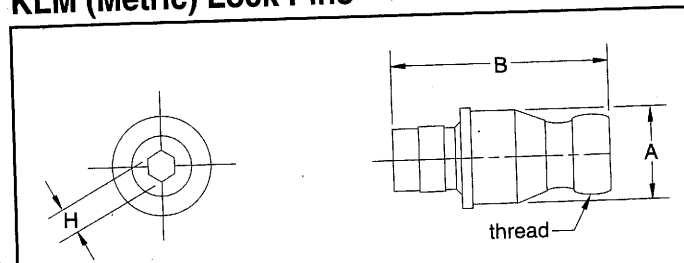

catalog number	A	B	H	threads
KLM-33L	.219	.410	2,0	M5 x 0,8
KLM-43	.219	.425	2,0	M5 x 0,8
KLM-56	.373	.701	3,0	M8 x 1
KLM-68	.435	.857	4,0	M10 x 1

KLC Lock Pins

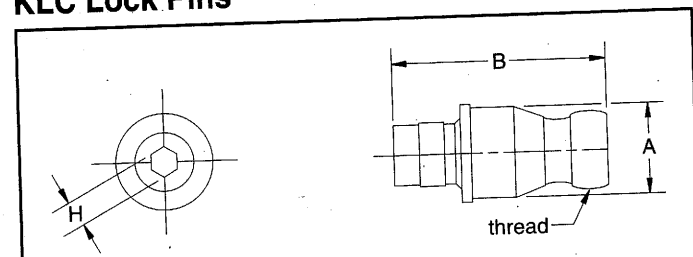

catalog number	A	B	H	threads
KLC-33	.219	.347	5/64	M5 x 0,8
KLC-33L	.219	.410	5/64	M5 x 0,8
KLC-34L	.219	.513	5/64	M5 x 0,8
KLC-43	.219	.425	5/64	M5 x 0,8
KLC-44	.281	.519	3/32	M6,3 x 1
KLC-46	.281	.676	3/32	M6,3 x 1
KLC-46S	.281	.616	3/32	M6,3 x 1
KLC-46L	.281	.733	3/32	M6,3 x 1
KLC-54	.281	.730	3/32	M6,3 x 1
KLC-56	.373	.701	1/8	M8 x 1
KLC-58	.373	.857	1/8	M8 x 1
KLC-68	.435	.857	9/64	M10 x 1
KLC-68L	.435	.948	9/64	M10 x 1

BP Bevel Lock Pins

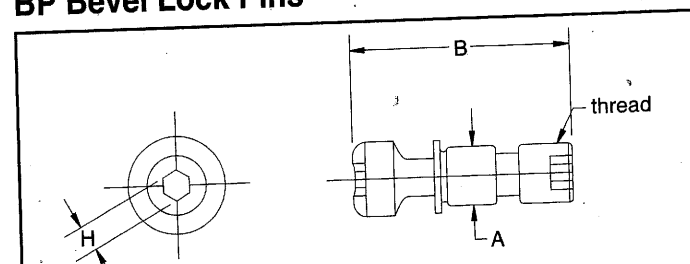

catalog number	A	B	H	threads
BP-46	.193	.730	3/32	10-24
BP-68	.256	1.140	1/8	1/4-20
BP-812	.342	1.437	9/64	5/16-18

Inserts

Toolholders

Boeing Bars & Heads

Drills

Collet Chucks

Cartridges

Brazed Tools

Technical Data

Index

Hardware (Clamp Screws)

STC Clamp Screws "XNS" ref

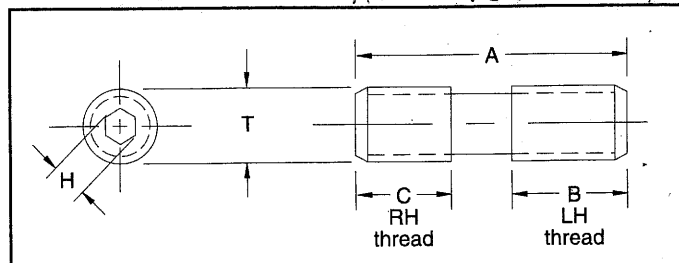

catalog number	A	B	C	"T" threads	H
STC-4	1.16	.50	.41	5/16-24	5/32
STC-5	.84	.31	.31	10-32	3/32
STC-8	1.00	.50	.25	5/16-24	5/32
STC-9	.59	.19	.19	10-32	3/32
STC-11	.81	.28	.28	1/4-28	1/8
STC-19	1.38	.50	.50	3/8-24	3/16
STC-20	1.16	.45	.45	1/4-28	1/8
STC-27	.38	.17	.17	8-36	5/64

STCC Clamp Screws

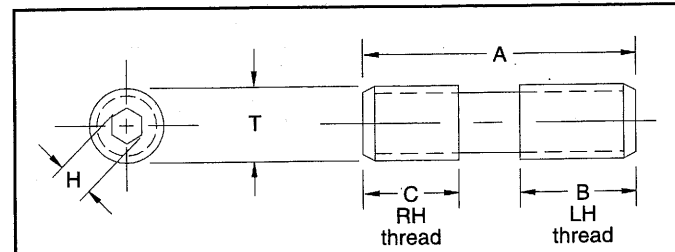

catalog number	A	B	C	"T" threads	H
STCC-8	1.00	.50	.25	M8 x 1,0	9/64
STCC-9	.59	.19	.19	M5 x 0,8	3/32
STCC-37	1.00	.50	.25	M8 x 1,0	3/32
STCC-38	.59	.19	.19	M5 x 0,8	5/64
STCC-39	1.06	.39	.39	M10 x 1,25	1/8
STCC-40	1.16	.45	.45	M6 x 1,0	3/32

STCM Clamp Screws

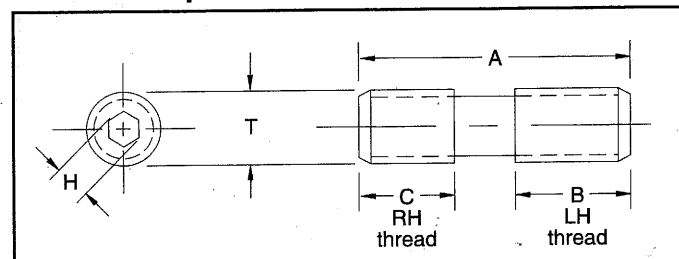

catalog number	A	B	C	"T" threads	H
STCM-11	.81	.28	.28	M6 x 1,0	3

Inserts

Toolholders

Boring Bars & Heads

Drills

Collet Chucks

Cartridges

Brazed Tools

Technical Data

Index

Technical Data

Cross Reference for Kendex-Style Toolholder Catalog Numbers

Inserts

Toolholders

Boring Bars & Heads

Drills

Collet Chucks

Cartridges

Braced Tools

Technical Data

Index

old cat. no.	new cat. no.
KCLL-124	CCLNL-124
KCLL-164	CCLNL-164
KCLL-206	CCLNL-206
KCLL-854	CCLNL-854
KCLL-866	CCLNL-866
KCLNL-163D	CCLNLP-163D
KCLNR-163D	CCLNRP-163D
KCLPL-124B	CCLPL-124B
KCLPL-164C	CCLPL-164C
KCLPL-164D	CCLPL-164D
KCLPL-204D	CCLPL-204D
KCLPR-124B	CCLPR-124B
KCLPR-164C	CCLPR-164C
KCLPR-164D	CCLPR-164D
KCLPR-204D	CCLPR-204D
KCLPR-84V	CCLPR-84V
KCLR-124	CCLNR-124
KCLR-164	CCLNR-164
KCLR-206	CCLNR-206
KCLR-854	CCLNR-854
KCLR-866	CCLNR-866
KCMPN-124B	CCMPN-124B
KCMPN-164D	CCMPN-164D
KCRNL-163D	CCRNLP-163D
KCRNR-163D	CCRNRP-163D
KRAL-123	CRGNL-123
KRAL-163	CRGNL-163
KRAL-164	CRGNL-164
KRAL-854	CRGNL-854
KRAL-864	CRGNL-864
KRAR-123	CRGNR-123
KRAR-163	CRGNR-163
KRAR-164	CRGNR-164
KRAR-854	CRGNR-854
KRAR-864	CRGNR-864
KRGNL-163D	CRGNLP-163D
KRGNL-164D	CRGNLP-164D
KRGNL-204D	CRGNLP-204D
KRGNR-163D	CRGNRP-163D
KRGNR-164D	CRGNRP-164D
KRGNR-204D	CRGNRP-204D
KSBL-103C	CSRPL-103B
KSBL-104	CSRNL-104
KSBL-124	CSRNL-124
KSBL-124C	CSRPL-124B
KSBL-164	CSRNL-164
KSBL-164C	CSRPL-164D
KSBL-166	CSRNL-166
KSBL-206	CSRNL-206
KSBL-83	CSRNL-083
KSBL-83C	CSRPL-083B
KSBL-854	CSRNL-854
KSBL-856	CSRNL-856
KSBL-856C	CSRPL-856D
KSBL-866	CSRNL-866
KSBL-866C	CSRPL-866E
KSBR-103C	CSRPR-103B
KSBR-104	CSRNR-104
KSBR-123	CSRNR-123

old cat. no.	new cat. no.
KSBR-124	CSRNR-124
KSBR-124C	CSRPR-124B
KSBR-164	CSRNR-164
KSBR-164C	CSRPR-164D
KSBR-166	CSRNR-166
KSBR-206	CSRNR-206
KSBR-83	CSRNR-083
KSBR-83C	CSRPR-083B
KSBR-854	CSRNR-854
KSBR-856	CSRNR-856
KSBR-856C	CSRPR-856D
KSBR-866	CSRNR-866
KSBR-866C	CSRPR-866E
KSDL-103	CSSNL-103
KSDL-123	CSSNL-123
KSDL-124	CSSNL-124
KSDL-164	CSSNL-164
KSDL-854	CSSNL-854
KSDL-854C	CSSPL-854D
KSDL-856	CSSNL-856
KSDL-866	CSSNL-866
KSDN-103	CSDNN-103
KSDN-103C	CSDPN-103
KSDN-124	CSDNN-124
KSDN-124C	CSDPN-124
KSDN-164	CSDNN-164
KSDN-164C	CSDPN-164
KSDN-644	CSDNN-644
KSDN-644C	CSDPN-644
KSDN-654	CSDNN-654
KSDN-654C	CSDPN-654
KSDN-83	CSDNN-083
KSDN-856C	CSDPN-856
KSDN-866	CSDNN-866
KSDN-866C	CSDPN-866
KSDR-103	CSSNR-103
KSDR-123	CSSNR-123
KSDR-124	CSSNR-124
KSDR-164	CSSNR-164
KSDR-164C	CSSPR-164D
KSDR-166C	CSSPR-166D
KSDR-854	CSSNR-854
KSDR-854C	CSSPR-854D
KSDR-856	CSSNR-856
KSDR-856C	CSSPR-856D
KSDR-866	CSSNR-866
KSFL-123	CSKNL-123
KSFL-124C	CSKPL-124B
KSFL-164	CSKNL-164
KSFL-164C	CSKPL-164D
KSFL-854	CSKNL-854
KSFL-856	CSKNL-856
KSFL-856C	CSKPL-856D
KSFR-123	CSKNR-123
KSFR-124C	CSKPR-124B
KSFR-164	CSKNR-164
KSFR-164C	CSKPR-164D
KSFR-854	CSKNR-854
KSFR-856	CSKNR-856
KSFR-856C	CSKPR-856D
KSFR-866	CSKNR-866
KSFR-866C	CSKPR-866E

old cat. no.	new cat. no.
KSKNL-164D	CSKNLP-164D
KSKNR-164D	CSKNRP-164D
KSRNL-163D	CSRNLP-163D
KSRNL-164D	CSRNLP-164D
KSRNR-163D	CSRNRP-163D
KSRNR-164D	CSRNRP-164D
KTAL-102	CTANL-102
KTAL-102C	CTAPL-102B
KTAL-123	CTANL-123
KTAL-123C	CTAPL-123B
KTAL-163	CTANL-163
KTAL-163C	CTAPL-163D
KTAL-164	CTANL-164
KTAL-245	CTANL-245
KTAL-82	CTANL-082
KTAL-82C	CTAPL-082B
KTAL-853	CTANL-853
KTAL-854	CTANL-854
KTAL-854C	CTAPL-854D
KTAL-864	CTANL-864
KTAL-864C	CTAPL-864E
KTAR-102	CTANR-102
KTAR-102C	CTAPR-102B
KTAR-123	CTANR-123
KTAR-123C	CTAPR-123B
KTAR-163	CTANR-163
KTAR-163C	CTAPR-163D
KTAR-164	CTANR-164
KTAR-204	CTANR-204
KTAR-245	CTANR-245
KTAR-643	CTANR-643
KTAR-82	CTANR-082
KTAR-82C	CTAPR-082B
KTAR-853	CTANR-853
KTAR-854	CTANR-854
KTAR-854C	CTAPR-854D
KTAR-864	CTANR-864
KTAR-864C	CTAPR-864E
KTBL-102	CTBNL-102
KTBL-102C	CTBPL-102B
KTBL-123	CTBNL-123
KTBL-123C	CTBPL-123B
KTBL-163	CTBNL-163
KTBL-163C	CTBPL-163D
KTBL-204	CTBNL-204
KTBL-245	CTBNL-245
KTBL-854C	CTBPL-854D
KTBL-864	CTBNL-864
KTBR-102	CTBNR-102
KTBR-102C	CTBPR-102B
KTBR-103	CTBNR-103
KTBR-123	CTBNR-123
KTBR-123C	CTBPR-123B
KTBR-163	CTBNR-163
KTBR-163C	CTBPR-163D
KTBR-204	CTBNR-204
KTBR-245	CTBNR-245
KTBR-643	CTBNR-643
KTBR-854C	CTBPR-854D
KTBR-864	CTBNR-864
KTCN-124C	CTCPN-124

old cat. no.	new cat. no.
KTCN-443C	CTCPN-443
KTCN-644C	CTCPN-644
KTCN-664C	CTCPN-664
KTCPL-123B	CTCPL-123B
KTCPL-163C	CTCPL-163C
KTCPL-164C	CTCPL-164C
KTCPL-164D	CTCPL-164D
KTCPL-204D	CTCPL-204D
KTCPL-205D	CTCPL-205D
KTCPL-244D	CTCPL-244D
KTCPL-854D	CTCPL-854D
KTCPL-865D	CTCPL-865D
KTCPR-123A	CTCPR-123A
KTCPR-123B	CTCPR-123B
KTCPR-163C	CTCPR-163C
KTCPR-164C	CTCPR-164C
KTCPR-164D	CTCPR-164D
KTCPR-204D	CTCPR-204D
KTCPR-205D	CTCPR-205D
KTCPR-244D	CTCPR-244D
KTCPR-854D	CTCPR-854D
KTCPR-865D	CTCPR-865D
KTDL-102	CTENL-102
KTDL-102C	CTEPL-102B
KTDL-103	CTENL-103
KTDL-123	CTENL-123
KTDL-123C	CTEPL-123B
KTDL-163	CTENL-163
KTDL-163C	CTEPL-163D
KTDL-643	CTENL-643
KTDL-854	CTENL-854
KTDL-854C	CTEPL-854D
KTDL-864C	CTEPL-864E
KTDL-865	CTENL-865
KTDR-102	CTENR-102
KTDR-102C	CTEPR-102B
KTDR-103	CTENR-103
KTDR-123	CTENR-123
KTDR-123C	CTEPR-123B
KTDR-163	CTENR-163
KTDR-163C	CTEPR-163D
KTDR-643	CTENR-643
KTDR-653	CTENR-653
KTDR-854	CTENR-854
KTDR-854C	CTEPR-854D
KTDR-864	CTENR-864
KTDR-864C	CTEPR-864E
KTDR-865	CTENR-865
KTFL-102	CTFNL-102
KTFL-102C	CTFPL-102B
KTFL-103	CTFNL-103
KTFL-123	CTFNL-123
KTFL-123C	CTFPL-123B
KTFL-163	CTFNL-163
KTFL-163C	CTFPL-163C
KTFL-204	CTFNL-204
KTFL-204C	CTFPL-204D
KTFL-643	CTFNL-643
KTFL-82C	CTFPL-082B
KTFL-853	CTFNL-853
KTFL-854	CTFNL-854
KTFL-854C	CTFPL-854D

Cross Reference for Kendex-Style Toolholder Catalog Numbers (Cont'd)

old cat. no.	new cat. no.
KTFL-864	CTFNL-864
KTFL-864C	CTFPL-864E
KTFL-865	CTFNL-865
KTFL-865C	CTFPL-865E
KTFFPL-123B	CTFFPL-123B
KTFFPL-163C	CTFFPL-163C
KTFFPL-164C	CTFFPL-164C
KTFFPL-204D	CTFFPL-204D
KTFFPL-205D	CTFFPL-205D
KTFFPL-854D	CTFFPL-854D
KTFFPR-123A	CTFFPR-123A
KTFFPR-123B	CTFFPR-123B
KTFFPR-163C	CTFFPR-163C
KTFFPR-164C	CTFFPR-164C
KTFFPR-164D	CTFFPR-164D
KTFFPR-204D	CTFFPR-204D
KTFFPR-205D	CTFFPR-205D
KTFFPR-82V	CTFFPR-082V
KTFFPR-854D	CTFFPR-854D
KTFR-102	CTFNR-102
KTFR-102C	CTFPR-102B
KTFR-103	CTFNR-103
KTFR-123	CTFNR-123
KTFR-123C	CTFPR-123B
KTFR-163	CTFNR-163
KTFR-163C	CTFPR-163D
KTFR-204	CTFNR-204
KTFR-204C	CTFPR-204D
KTFR-244	CTFNR-244
KTFR-643	CTFNR-643
KTFR-653	CTFNR-653
KTFR-82C	CTFPR-082B

old cat. no.	new cat. no.
KTFR-853	CTFNR-853
KTFR-854	CTFNR-854
KTFR-854C	CTFPR-854D
KTFR-864	CTFNR-864
KTFR-864C	CTFPR-864E
KTFR-865	CTFNR-865
KTFR-865C	CTFPR-865E
KTGL-102C	CTGPL-102B
KTGL-103	CTGNL-103
KTGL-123	CTGNL-123
KTGL-123C	CTGPL-123B
KTGL-163	CTGNL-163
KTGL-163C	CTGPL-163C
KTGL-164	CTGNL-164
KTGL-204	CTGNL-204
KTGL-204C	CTGPL-204D
KTGL-205	CTGNL-205
KTGL-244	CTGNL-244
KTGL-245	CTGNL-245
KTGL-853	CTGNL-853
KTGL-854C	CTGPL-854D
KTGL-864	CTGNL-864
KTGL-864C	CTGPL-864E
KTGL-865C	CTGPL-865E
KTGNL-122B	CTGNLP-122B
KTGPR-122B	CTGNRP-122B
KTGPL-123B	CTGPL-123B
KTGPL-163C	CTGPL-163C
KTGPL-164C	CTGPL-164C
KTGPL-164D	CTGPL-164D
KTGPL-204D	CTGPL-204D
KTGPL-205D	CTGPL-205D

old cat. no.	new cat. no.
KTGPR-123A	CTGPR-123A
KTGPR-123B	CTGPR-123B
KTGPR-163C	CTGPR-163C
KTGPR-164C	CTGPR-164C
KTGPR-164D	CTGPR-164D
KTGPR-204D	CTGPR-204D
KTGPR-205D	CTGPR-205D
KTGPR-82V	CTGPR-082V
KTGPR-854D	CTGPR-854D
KTGR-102C	CTGPR-102B
KTGR-103	CTGPR-103
KTGR-123	CTGPR-123
KTGR-123C	CTGPR-123B
KTGR-163	CTGPR-163
KTGR-163C	CTGPR-163D
KTGR-164	CTGPR-164
KTGR-204	CTGPR-204
KTGR-204C	CTGPR-204D
KTGR-205	CTGPR-205
KTGR-244	CTGPR-244
KTGR-245	CTGPR-245
KTGR-853	CTGPR-853
KTGR-854C	CTGPR-854D
KTGR-864	CTGPR-864
KTGR-864C	CTGPR-864E
KTGR-865	CTGPR-865
KTGR-865C	CTGPR-865E
NELL-1005B	NKLCL-1005B
NELL-1205A	NKLCL-1205A
NELL-1205B	NKLCL-1205B
NELL-121B	NKLNL-121B
NELL-161C	NKLNL-161C

old cat. no.	new cat. no.
NELL-163C	NKLNL-163C
NELL-163D	NKLNL-163D
NELL-203D	NKLNL-203D
NELL-805V	NKLCL-0805V
NELL-863D	NKLNL-863D
NELLF-805D	NKLCLF-0805D
NELR-1005B	NKLCR-1005B
NELR-1205A	NKLCR-1205A
NELR-1205B	NKLCR-1205B
NELR-121B	NKLN-121B
NELR-161C	NKLN-161C
NELR-163C	NKLN-163C
NELR-163D	NKLN-163D
NELR-203D	NKLN-203D
NELR-805V	NKLCR-0805V
NELR-863D	NKLN-863D
NELRF-805D	NKLCR-805D
NEPN-1205B	NKPCN-1205B
NEPN-805D	NKPCN-805D
NEPN-805V	NKPCN-805V

Inserts
 Toolholders
 Boring Bars & Heads
 Drills
 Collet Chucks
 Cartridges
 Brazed Tools
 Technical Data
 Index

Technical Data

Boring Bar Construction (suggested length/diameter ratios)

length/diameter ratio	boring bar
to 4:1 from 4:1 to 6:1 from 4:1 to 6:1 from 6:1 to 8:1 from 8:1 to 10:1 over 10:1	steel* steel with De Vibrator* tungsten carbide* tungsten carbide with De Vibrator* tungsten carbide composite with De Vibrator* special tungsten carbide composite with De Vibrator*

*Standard commercial boring bar.

Mounting Dimensions for Interchangeable Boring Heads

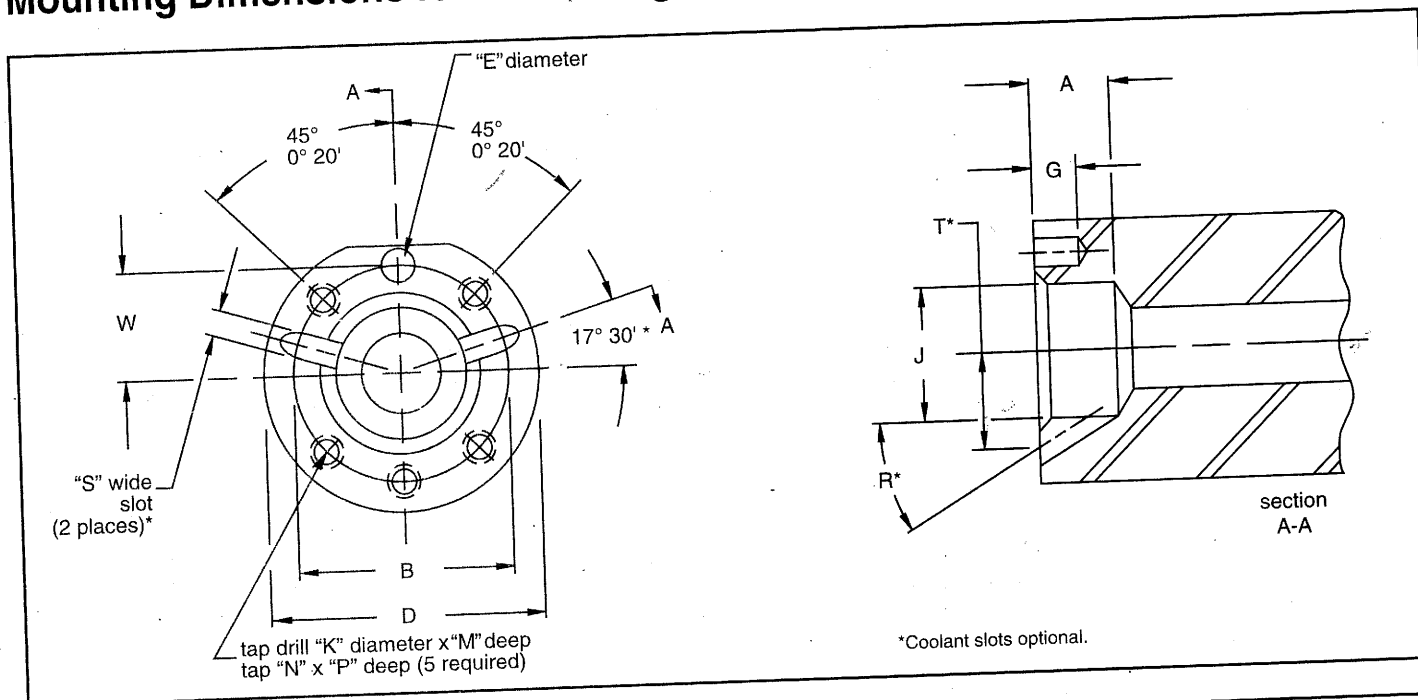

D	A	B ±.005	E +.0010 -.0000	G	J +.0005 -.0000	K	M	N	P	W ±.001	R	S	T	screw cat. no.	
														3 req'd	1 req'd
1	.32	.698	.1615	.25	.4500	.1285	.75	8-32 UNC	.69	.349	24°	.125	.349	S-319	S-322
1 1/4	.44	.907	.1915	.25	.6250	.1495	.75	10-24 UNC	.69	.453	26°	.125	.453	S-327	S-330
1 1/2	.44	1.125	.1915	.25	.7500	.1495	.75	10-24 UNC	.69	.562	30°	.125	.562	S-327	S-330
1 3/4	.56	1.312	.2540	.31	.8750	.2040	.75	1/4-20 UNC	.69	.656	30°	.156	.656	S-337	S-340
2	.56	1.563	.2540	.31	1.1250	.2040	.75	1/4-20 UNC	.69	.781	30°	.188	.781	S-337	S-340
2 1/4	.56	1.780	.2540	.31	1.3120	.2040	.75	1/4-20 UNC	.69	.890	30°	.188	.890	S-337	S-340
2 1/2	.56	1.969	.2540	.31	1.5000	.2610	1.00	5/16-18 UNC	.88	.984	30°	.188	.984	S-350	S-353

Dowel Pins

head diameter "D"	dowel pin catalog number	pin diameter	pin length	old catalog number
1	HDPM-040-010	4 mm	10 mm	MS-1074
1 1/4	HDP-188-0375	.1875	.375	S-947
1 1/2	HDP-188-0375	.1875	.375	S-947
1 3/4	HDP-250-0500	.2500	.500	S-948
2	HDP-250-0500	.2500	.500	S-948
2 1/4	HDP-250-0500	.2500	.500	S-948
2 1/2	HDP-250-0500	.2500	.500	S-948

Cross Reference for Boring Bar Catalog Numbers (Cont'd)

old cat. no.	new cat. no.
1011	H20-CTFPR3W
1021	H20-CSKPR4W
1025	H20-NER3W
1027	H20-NRR3
1031	H20-DTFNR3W
1034	H20-DVUNR3W
1036	H20-DDUNR4W
1037	H20-DCLNR4W
1041	H20-DSKNR4W
1047	H20-DCKNR4W
1059	H20-CCLPR4W
1063	H20-DDPNR4W
1092	H20-DSSNR4W
1096	H20-DCFNR4W
1211	H24-CTFPR3W
1212	H24-CTFPR4W
1221	H24-CSKPR4W
1225	H24-NER3W
1227	H24-NRR3
1231	H24-DTFNR3W
1234	H24-DVUNR3W
1235	H24-DCLNR5W
1236	H24-DDUNR4W
1237	H24-DCLNR4W
1241	H24-DSKNR4W
1247	H24-DCKNR4W
1259	H24-CCLPR4W
1263	H24-DDPNR4W
1292	H24-DSSNR4W
1296	H24-DCFNR4W
1411	H28-CTFPR3W
1412	H28-CTFPR4W
1421	H28-CSKPR4W
1425	H28-NER3W
1426	H28-NER4W
1431	H28-DTFNR3W
1436	H28-DDUNR4W
1437	H28-DCLNR4W
1441	H28-DSKNR4W
1492	H28-DSSNR4W
1612	H32-CTFPR4W
1622	H32-CSKPR6W
1625	H32-NER3W
1626	H32-NER4W
1632	H32-DTFNR4W
1635	H32-DCLNR5W
1636	H32-DDUNR4W
1637	H32-DCLNR4W
1638	H32-DCLNR6W
1639	H32-DCFNR6W
1642	H32-DSKNR6W
1643	H32-DVUNR4W
1648	H32-DCKNR6W
1658	H32-CCLPR6W
1693	H32-DSSNR6W
1812	H36-CTFPR4W
1822	H36-CSKPR6W
1826	H36-NER4W
1832	H36-DTFNR4W
1836	H36-DDUNR4W
1838	H36-DCLNR6W

old cat. no.	new cat. no.
1842	H36-DSKNR6W
2012	H40-CTFPR4W
2022	H40-CSKPR6W
2025	H40-NER3W
2026	H40-NER4W
2032	H40-DTFNR4W
2036	H40-DDUNR4W
2038	H40-DCLNR6W
2039	H40-DCFNR6W
2042	H40-DSKNR6W
2043	H40-DVUNR4W
2048	H40-DCKNR6W
2058	H40-KCLPR6W
2093	H40-DSSNR6W
16100	H32-DTFNR5W
16105	H32-DCKNR5W
16106	H32-DCFNR5W
03-112	06-STFPR2H
03-112L	06-STFPL2H
03-116	06-SCLPR2H
03-116L	06-SCLPL2H
0370H	06-STFPR2HA
0370LH	06-STFPL2HA
0377H	06-STUNR2H
0377LH	06-STUNL2H
04-112	08-STFPR2
04-112L	08-STFPL2
04-116	08-SCLPR2
04-116L	08-SCLPL2
0470T	08-CTFPR2
0470TL	08-CTFPL2
0471H	08-NKLCR05
0471LH	08-NKLCLO5
0477H	08-STUNR2
0477LH	08-STUNL2
05-112	10-STFPR2
05-112L	10-STFPL2
05-116	10-SCLPR2
05-116L	10-SCLPL2
0570A	10-CTFPR2
0570AL	10-CTFPL2
0571H	10-NKLCR05
0571LH	10-NKLCLO5
0576H	10-NER2
0576HL	10-NEL2
0577H	10-STUNR2
0577LH	10-STUNL2
06-117	12-SCLPR3
06-117L	12-SCLPL3
0670A	12-CTFPR3
0670AL	12-CTFPL3
0671H	12-NKLCR05
0671LH	12-NKLCLO5
0676H	12-NER2
0676HL	12-NEL2
0678H	12-STUNR3
0678LH	12-STUNL3
08-117	16-SCLPR3

old cat. no.	new cat. no.
08-117L	16-SCLPL3
08-KTFPL2H	08-CTFPL2
08-KTFPR2H	08-CTFPR2
08-NELL05H	08-NKLCLO5
08-NELR05H	08-NKLCR05
08-SCLPL2H	08-SCLPL2
08-SCLPR2H	08-SCLPR2
08-STFPL2H	08-STFPL2
08-STFPR2H	08-STFPR2
08-STUNL2H	08-STUNL2
08-STUNR2H	08-STUNR2
0870A	16-CTFPR3
0870AL	16-CTFPL3
0875H	16-NER3
0875HL	16-NEL3
0878H	16-STUNR3
0878HL	16-STUNL3
10-KTFPL2H	10-CTFPL2
10-KTFPR2H	10-CTFPR2
10-NEL2H	10-NEL2
10-NELL05H	10-NKLCLO5
10-NELR05H	10-NKLCR05
10-NER2H	10-NER2
10-SCLPL2H	10-SCLPL2
10-SCLPR2H	10-SCLPR2
10-STFPL2H	10-STFPL2
10-STFPR2H	10-STFPR2
10-STUNL2H	10-STUNL2
10-STUNR2H	10-STUNR2
1011L	H20-CTFPL3W
1021L	H20-CSKPL4W
1025L	H20-NEL3W
1031L	H20-DTFNL3W
1034L	H20-DVUNL3W
1036L	H20-DDUNL4W
1037L	H20-DCLNL4W
1041L	H20-DSKNL4W
1047L	H20-DCKNL4W
1063L	H20-DDPNL4W
1096L	H20-DCFNL4W
12-KTFPL3H	12-CTFPL3
12-KTFPR3H	12-CTFPR3
12-NEL2H	12-NEL2
12-NELL05H	12-NKLCLO5
12-NELR05H	12-NKLCR05
12-NER2H	12-NER2
12-SCLPL3H	12-SCLPL3
12-SCLPR3H	12-SCLPR3
12-STUNL3H	12-STUNL3
12-STUNR3H	12-STUNR3
1211L	H24-CTFPL3W
1212L	H24-CTFPL4W
1221L	H24-CSKPL4W
1225L	H24-NEL3W
1231L	H24-DTFNL3W
1234L	H24-DVUNL3W

old cat. no.	new cat. no.
1235L	H24-DCLNL5W
1236L	H24-DDUNL4W
1237L	H24-DCLNL4W
1241L	H24-DSKNL4W
1247L	H24-DCKNL4W
1263L	H24-DDPNL4W
1296L	H24-DCFNL4W
1411L	H28-CTFPL3W
1412L	H28-CTFPL4W
1421L	H28-CSKPL4W
1425L	H28-NEL3W
1426L	H28-NEL4W
1431L	H28-DTFNL3W
1436L	H28-DDUNL4W
1437L	H28-DCLNL4W
1441L	H28-DSKNL4W
16-KTFPL3H	16-CTFPL3
16-KTFPR3H	16-CTFPR3
16-NEL3H	16-NEL3
16-NER3H	16-NER3
16-SCLPL3H	16-SCLPL3
16-SCLPR3H	16-SCLPR3
16-STUNL3H	16-STUNL3
16-STUNR3H	16-STUNR3
16105L	H32-DCKNL5W
16106L	H32-DCFNL5W
1612L	H32-CTFPL4W
1625L	H32-NEL3W
1626L	H32-NEL4W
1632L	H32-DTFNL4W
1635L	H32-DCLNL5W
1636L	H32-DDUNL4W
1638L	H32-DCLNL6W
1639L	H32-DCFNL6W
1642L	H32-DSKNL6W
1643L	H32-DVUNL4W
1648L	H32-DCKNL6W
1812L	H36-CTFPL4W
1826L	H36-NEL4W
1832L	H36-DTFNL4W
1836L	H36-DDUNL4W
1838L	H36-DCLNL6W
1842L	H36-DSKNL6W
20100W	H40-DTFNR5W
2012L	H40-CTFPL4W
2025L	H40-NEL3W
2026L	H40-NEL4W
2032L	H40-DTFNL4W
2036L	H40-DDUNL4W
2038L	H40-DCLNL6W
2039L	H40-DCFNL6W
2042L	H40-DSKNL6W
2043L	H40-DVUNL4W
2048L	H40-DCKNL6W
B-4410W	S-4420W
B-4412W	S-4424W
B-4414W	S-4428W
B-4416W	S-4432W
B-4418W	S-4436W
B-4420W	S-4440W
B-4420W24	S-4440W48

Inserts

Toolholders

Boring Bars & Heads

Drills

Collet Chucks

Cartridges

Brazed Tools

Technical Data

Index

Technical Data

Cross Reference for Boring Bar Catalog Numbers (Cont'd)

Inserts

Toolholders

Boring Bars & Heads

Drills

Collet Chucks

Cartridges

Brazed Tools

Technical Data

Index

old cat. no.	new cat. no.
B-5410	D-5420W
B-5412	D-5424W
B-5414	D-5428W
B-5416	D-5432W
B-5418	D-5436W
B-5420	D-5440W
B-6410	C-6420
B-6412	C-11924W
B-6414	C-11928W
B-6416	C-11932W
B-6418	C-11936W
B-6420	C-11940W
B10016	A32-CTFNR5
B1003	A06-CTFPR2
B1004	A08-CTFPR2
B1005	A10-CTFPR2
B10105	A10-NER1
B10203	A06-NER1
B10204	A08-NER1
B10416	A32-NER6
B10420	A40-NER6
B10516	A32-DCKNR5
B10612	A24-DCFNR5
B10616	A32-DCFNR5
B10704	A08-NKQCR05
B10706	A12-NKQCR05
B1106	A12-CTFPR3
B1108	A16-CTFPR3
B1110	A20-CTFPR3
B1112	A24-CTFPR3
B1114	A28-CTFPR3
B11203	A06-STFPR2
B11204	A08-STFPR2
B11205	A10-STFPR2
B11403	A06-SCFPR2
B11404	A08-SCFPR2
B11405	A10-SCFPR2
B11506	A12-SCFPR3
B11508	A16-SCFPR3
B11603	A06-SCLPR2
B11604	A08-SCLPR2
B11605	A10-SCLPR2
B11706	A12-SCLPR3
B11708	A16-SCLPR3
B1212	A24-CTFPR4
B1214	A28-CTFPR4
B1216	A32-CTFPR4
B1220	A40-CTFPR4
B1503	A06-STUNR2
B1504	A08-STUNR2
B1505	A10-STUNR2
B1555	A0610-STUNL2
B1606	A12-STUNR3
B2108	A16-CSKPR4
B2110	A20-CSKPR4
B2112	A24-CSKPR4
B2114	A28-CSKPR4
B2214	A28-CSKPR6
B2216	A32-CSKPR6
B2220	A40-CSKPR6
B2508	A16-NER3

old cat. no.	new cat. no.
B2510	A20-NER3
B2512	A24-NER3
B2514	A28-NER3
B2516	A32-NER3
B2520	A40-NER3
B2614	A28-NER4
B2616	A32-NER4
B2618	A36-NER4
B2620	A40-NER4
B2905	A10-NER2
B2906	A12-NER2
B2908	A16-NER2
B3108	A16-DTFNR3
B3110	A20-DTFNR3
B3112	A24-DTFNR3
B3114	A28-DTFNR3
B3216	A32-DTFNR4
B3218	A36-DTFNR4
B3220	A40-DTFNR4
B3410	A20-DVUNR3
B3412	A24-DVUNR3
B3512	A24-DCLNR5
B3516	A32-DCLNR5
B3610	A20-DDUNR4
B3612	A24-DDUNR4
B3614	A28-DDUNR4
B3616	A32-DDUNR4
B3708	A16-DCLNR4
B3710	A20-DCLNR4
B3712	A24-DCLNR4
B3714	A28-DCLNR4
B3716	A32-DCLNR4
B3816	A32-DCLNR6
B3818	A36-DCLNR6
B3820	A40-DCLNR6
B3916	A32-DCFNR6
B3920	A40-DCFNR6
B4110	A20-DSKNR4
B4112	A24-DSKNR4
B4114	A28-DSKNR4
B4216	A32-DSKNR6
B4218	A36-DSKNR6
B4220	A40-DSKNR6
B4316	A32-DVUNR4
B4320	A40-DVUNR4
B4510	A20-DDQNR4
B4512	A24-DDQNR4
B4616	A32-NER5
B4620	A40-NER5
B4710	A20-DCKNR4
B4712	A24-DCKNR4
B4820	A40-DCKNR6
B4903	A06-CTLPR2
B4904	A08-CTLPR2
B4906	A12-CTLPR3
B4908	A16-CTLPR3
B5005	B10-CTFPR2
B5006	B12-CTFPR3

old cat. no.	new cat. no.
B5007	B14-CTFPR3
B5008	B16-CTFPR3
B5010	B20-CTFPR3
B5012	B24-CTFPR4
B5014	B28-CTFPR4
B5016	B32-CTFPR4
B5020	B40-CTFPR4
B5908	A16-CCLPR4
B5910	A20-CCLPR4
B5912	A24-CCLPR4
B5914	A28-CCLPR4
B6310	A20-DDPNR4
B6312	A24-DDPNR4
B7003	E06D-STFPR2
B7004	E08F-CTFPR2
B7005A	E10S-CTFPR2
B7006A	E12S-CTFPR3
B7008A	E16T-CTFPR3
B7104	E08-NKLCR05
B7105	E10-NKLCR05
B7106	E12-NKLCR05
B711203	E06-STFPR2
B711204	E08-STFPR2
B711205	E10-STFPR2
B711603	E06-SCLPR2
B711604	E08-SCLPR2
B711605	E10-SCLPR2
B711706	E12-SCLPR3
B711708	E16-SCLPR3
B7203	E06A-CTFPR2
B7204	E08C-CTFPR2
B7205A	E10D-CTFPR2
B7206A	E12E-CTFPR3
B7208A	E16R-CTFPR3
B7508	E16-NER3
B7605	E10-NER2
B7606	E12-NER2
B7703	E06-STUNR2
B7704	E08-STUNR2
B7705	E10-STUNR2
B7806	E12-STUNR3
B7808	E16-STUNR3
B7908	E16-NKLNLR1
B8205	A10-NKLCR05
B8206	A12-NKLCR05
B9608	A16-DCFNR4
B9610	A20-DCFNR4
B9612	A24-DCFNR4
BL1003	A06-CTFPL2
BL1004	A08-CTFPL2
BL1005	A10-CTFPL2
BL10416	A32-NEL6
BL10516	A32-DCKNL5
BL10612	A24-DCFNL5
BL10616	A32-DCFNL5
BL10704	A08-NKQCL05
BL10706	A12-NKQCL05
BL1106	A12-CTFPL3
BL1108	A16-CTFPL3
BL1110	A20-CTFPL3

old cat. no.	new cat. no.
BL1112	A24-CTFPL3
BL1114	A28-CTFPL3
BL11403	A06-SCFPL2
BL11404	A08-SCFPL2
BL11405	A10-SCFPL2
BL11506	A12-SCFPL3
BL11508	A16-SCFPL3
BL11603	A06-SCLPL2
BL11604	A08-SCLPL2
BL11605	A10-SCLPL2
BL11706	A12-SCLPL3
BL11708	A16-SCLPL3
BL1212	A24-CTFPL4
BL1214	A28-CTFPL4
BL1216	A32-CTFPL4
BL1220	A40-CTFPL4
BL1503	A06-STUNL2
BL1504	A08-STUNL2
BL1505	A10-STUNL2
BL1555	A0610-STUNR2
BL1606	A12-STUNL3
BL2508	A16-NEL3
BL2510	A20-NEL3
BL2512	A24-NEL3
BL2514	A28-NEL3
BL2516	A32-NEL3
BL2520	A40-NEL3
BL2614	A28-NEL4
BL2616	A32-NEL4
BL2618	A36-NEL4
BL2620	A40-NEL4
BL2905	A10-NEL2
BL2906	A12-NEL2
BL2908	A16-NEL2
BL3108	A16-DTFNL3
BL3110	A20-DTFNL3
BL3112	A24-DTFNL3
BL3114	A28-DTFNL3
BL3216	A32-DTFNL4
BL3218	A36-DTFNL4
BL3220	A40-DTFNL4
BL3410	A20-DVUNL3
BL3412	A24-DVUNL3
BL3512	A24-DCLNL5
BL3516	A32-DCLNL5
BL3610	A20-DDUNL4
BL3612	A24-DDUNL4
BL3614	A28-DDUNL4
BL3616	A32-DDUNL4
BL3708	A16-DCLNL4
BL3710	A20-DCLNL4
BL3712	A24-DCLNL4
BL3714	A28-DCLNL4
BL3816	A32-DCLNL6
BL3818	A36-DCLNL6
BL3820	A40-DCLNL6
BL3916	A32-DCFNL6
BL3920	A40-DCFNL6
BL4110	A20-DSKNL4

Cross Reference for Boring Bar Catalog Numbers (Cont'd)

old cat. no.	new cat. no.
BL4112	A24-DSKNL4
BL4114	A28-DSKNL4
BL4216	A32-DSKNL6
BL4218	A36-DSKNL6
BL4220	A40-DSKNL6
BL4316	A32-DVUNL4
BL4320	A40-DVUNL4
BL4510	A20-DDQNL4
BL4512	A24-DDQNL4
BL4616	A32-NEL5
BL4710	A20-DCKNL4
BL4712	A24-DCKNL4
BL4820	A40-DCKNL6
BL4903	A06-CTLPL2
BL4904	A08-CTLPL2
BL4906	A12-CTLPL3
BL4908	A16-CTLPL3
BL5908	A16-CCLPL4
BL5910	A20-CCLPL4
BL5912	A24-CCLPL4
BL5914	A28-CCLPL4
BL6310	A20-DDPNL4
BL6312	A24-DDPNL4
BL7003	E06D-STFPL2
BL7004	E08F-CTFPL2
BL7005A	E10S-CTFPL2
BL7006A	E12S-CTFPL3
BL7008A	E16T-CTFPL3
BL7104	E08-NKLCL05
BL7105	E10-NKLCL05
BL7106	E12-NKLCL05
BL711603	E06-SCLPL2
BL711604	E08-SCLPL2
BL711605	E10-SCLPL2
BL711706	E12-SCLPL3
BL711708	E16-SCLPL3
BL7203	E06A-STFPL2
BL7204	E08C-CTFPL2
BL7205A	E10D-CTFPL2
BL7206A	E12E-CTFPL3
BL7208A	E16R-CTFPL3
BL7508	E16-NEL3
BL7605	E10-NEL2
BL7606	E12-NEL2
BL7703	E06-STUNL2
BL7704	E08-STUNL2
BL7705	E10-STUNL2
BL7806	E12-STUNL3
BL7808	E16-STUNL3
BL8206	A12-NKLCL05
BL9608	A16-DCFNL4
BL9610	A20-DCFNL4
BL9612	A24-DCFNL4
C06-SCLPL2	E06-SCLPL2
C06-SCLPR2	E06-SCLPR2
C06-STFPL2	E06-STFPL2
C06-STFPR2	E06-STFPR2
C06-STUNL2	E06-STUNL2

old cat. no.	new cat. no.
C06-STUNR2	E06-STUNR2
C08-NELL05	E08-NKLCL05
C08-NELR05	E08-NKLCR05
C08-SCLPL2	E08-SCLPL2
C08-SCLPR2	E08-SCLPR2
C08-STFPL2	E08-STFPL2
C08-STFPR2	E08-STFPR2
C08-STUNL2	E08-STUNL2
C08-STUNR2	E08-STUNR2
C08C-KTFPL2	E08C-CTFPL2
C08C-KTFPR2	E08C-CTFPR2
C08F-KTFPL2	E08F-CTFPL2
C08F-KTFPR2	E08F-CTFPR2
C10-NEL2	E10-NEL2
C10-NELL05	E10-NKLCL05
C10-NELR05	E10-NKLCR05
C10-NER2	E10-NER2
C10-SCLPL2	E10-SCLPL2
C10-SCLPR2	E10-SCLPR2
C10-STFPL2	E10-STFPL2
C10-STFPR2	E10-STFPR2
C10-STUNL2	E10-STUNL2
C10-STUNR2	E10-STUNR2
C10D-KTFPL2	E10D-CTFPL2
C10D-KTFPR2	E10D-CTFPR2
C10S-KTFPL2	E10S-CTFPL2
C10S-KTFPR2	E10S-CTFPR2
C12-NEL2	E12-NEL2
C12-NELL05	E12-NKLCL05
C12-NELR05	E12-NKLCR05
C12-NER2	E12-NER2
C12-STUNL3	E12-STUNL3
C12-STUNR3	E12-STUNR3
C12E-KTFPL3	E12E-CTFPL3
C12E-KTFPR3	E12E-CTFPR3
C12S-KTFPL3	E12S-CTFPL3
C12S-KTFPR3	E12S-CTFPR3
C16-NEL3	E16-NEL3
C16-NER3	E16-NER3
C16-STUNL3	E16-STUNL3
C16-STUNR3	E16-STUNR3
C16R-KTFPL3	E16R-CTFPL3
C16R-KTFPR3	E16R-CTFPR3
C16T-KTFPL3	E16T-CTFPL3
C16T-KTFPR3	E16T-CTFPR3
D10-KTFPR2	B10-CTFPR2
D12-KTFPR3	B12-CTFPR3
D14-KTFPR3	B14-CTFPR3
D16-KTFPR3	B16-CTFPR3
D20-KTFPR3	B20-CTFPR3
D24-KTFPR4	B24-CTFPR4
D28-KTFPR4	B28-CTFPR4
D32-KTFPR4	B32-CTFPR4
D40-KTFPR4	B40-CTFPR4
H20-KCLPR4W	H20-CCLPR4W
H20-KSKPL4W	H20-CSKPL4W
H20-KSKPR4W	H20-CSKPR4W
H20-KTFPL3W	H20-CTFPL3W
H20-KTFPR3W	H20-CTFPR3W
H24-KCLPR4W	H24-CCLPR4W

old cat. no.	new cat. no.
H24-KSKPL4W	H24-CSKPL4W
H24-KSKPR4W	H24-CSKPR4W
H24-KTFPL3W	H24-CTFPL3W
H24-KTFPL4W	H24-CTFPL4W
H24-KTFPR3W	H24-CTFPR3W
H24-KTFPR4W	H24-CTFPR4W
H28-KSKPL4W	H28-CSKPL4W
H28-KSKPR4W	H28-CSKPR4W
H28-KTFPL3W	H28-CTFPL3W
H28-KTFPL4W	H28-CTFPL4W
H28-KTFPR3W	H28-CTFPR3W
H28-KTFPR4W	H28-CTFPR4W
H28-NEL6	H28-NEL6W
H28-NER6	H28-NER6W
H32-KCLPR6W	H32-CCLPR6W
H32-KSKPL6W	H32-CSKPL6W
H32-KSKPR6W	H32-CSKPR6W
H32-KTFPL4W	H32-CTFPL4W
H32-KTFPR4W	H32-CTFPR4W
H32-NEL6	H32-NEL6W
H32-NER6	H32-NER6W
H36-KSKPR6W	H36-CSKPR6W
H36-KTFPL4W	H36-CTFPL4W
H36-KTFPR4W	H36-CTFPR4W
H40-KCLPR4W	H40-CCLPR4W
H40-KSKPR6W	H40-CSKPR6W
H40-KTFPL4W	H40-CTFPL4W
H40-KTFPR4W	H40-CTFPR4W
H40-NEL6	H40-NEL6W
H40-NER6	H40-NER6W
S06-KTFPL2	A06-CTFPL2
S06-KTFPR2	A06-CTFPR2
S06-KTLPL2	A06-CTLPL2
S06-KTLPR2	A06-CTLPR2
S06-NEL1	A06-NEL1
S06-NER1	A06-NER1
S06-SCFPL2	A06-SCFPL2
S06-SCFPR2	A06-SCFPR2
S06-SCLPL2	A06-SCLPL2
S06-SCLPR2	A06-SCLPR2
S06-STFPR2	A06-STFPR2
S06-STUNL2	A06-STUNL2
S06-STUNR2	A06-STUNR2
S08-KTFPL2	A08-CTFPL2
S08-KTFPR2	A08-CTFPR2
S08-KTLPL2	A08-CTLPL2
S08-KTLPR2	A08-CTLPR2
S08-NEL1	A08-NEL1
S08-NEQL05	A08-NKQCL05
S08-NEQR05	A08-NKQCR05
S08-NER1	A08-NER1
S08-SCFPL2	A08-SCFPL2
S08-SCFPR2	A08-SCFPR2
S08-SCLPL2	A08-SCLPL2
S08-SCLPR2	A08-SCLPR2
S08-STFPR2	A08-STFPR2
S08-STUNL2	A08-STUNL2
S08-STUNR2	A08-STUNR2
S10-KTFPL2	A10-CTFPL2
S10-KTFPR2	A10-CTFPR2
S10-NEL1	A10-NEL1
S10-NEL2	A10-NEL2

old cat. no.	new cat. no.
S10-NELL05	A10-NKLCL05
S10-NELR05	A10-NKLCR05
S10-NER1	A10-NER1
S10-NER2	A10-NER2
S10-SCFPL2	A10-SCFPL2
S10-SCFPR2	A10-SCFPR2
S10-SCLPL2	A10-SCLPL2
S10-SCLPR2	A10-SCLPR2
S10-STFPR2	A10-STFPR2
S10-STUNL2	A10-STUNL2
S10-STUNR2	A10-STUNR2
S12-KTFPL3	A12-CTFPL3
S12-KTFPR3	A12-CTFPR3
S12-KTLPL3	A12-CTLPL3
S12-KTLPR3	A12-CTLPR3
S12-NEL2	A12-NEL2
S12-NELL05	A12-NKLCL05
S12-NELR05	A12-NKLCR05
S12-NEQL05	A12-NKQCL05
S12-NEQR05	A12-NKQCR05
S12-NER2	A12-NER2
S12-NEXL05	A12-NKXCL05
S12-NEXR05	A12-NKXCR05
S12-STUNL3	A12-STUNL3
S12-STUNR3	A12-STUNR3
S16-DCFNL4	A16-DCFNL4
S16-DCFNR4	A16-DCFNR4
S16-DCLNL4	A16-DCLNL4
S16-DCLNR4	A16-DCLNR4
S16-DTFNL3	A16-DTFNL3
S16-DTFNR3	A16-DTFNR3
S16-KCLPL4	A16-CCLPL4
S16-KCLPR4	A16-CCLPR4
S16-KSKPR4	A16-CSKPR4
S16-KTFPL3	A16-CTFPL3
S16-KTFPR3	A16-CTFPR3
S16-KTLPL3	A16-CTLPL3
S16-KTLPR3	A16-CTLPR3
S16-NEL2	A16-NEL2
S16-NEL3	A16-NEL3
S16-NELL05	A16-NKLCL05
S16-NELR05	A16-NKLCR05
S16-NEQL05	A16-NKQCL05
S16-NEQR05	A16-NKQCR05
S16-NER2	A16-NER2
S16-NER3	A16-NER3
S16-NEXL05	A16-NKXCL05
S16-NEXR05	A16-NKXCR05
S20-DCFNL4	A20-DCFNL4
S20-DCFNR4	A20-DCFNR4
S20-DCKNL4	A20-DCKNL4
S20-DCKNR4	A20-DCKNR4
S20-DCLNL4	A20-DCLNL4
S20-DCLNR4	A20-DCLNR4
S20-DDPNL4	A20-DDPNL4
S20-DDPNR4	A20-DDPNR4
S20-DDQNL4	A20-DDQNL4
S20-DDQNR4	A20-DDQNR4
S20-DDUNL4	A20-DDUNL4
S20-DDUNR4	A20-DDUNR4
S20-DSKNL4	A20-DSKNL4
S20-DSKNR4	A20-DSKNR4
S20-DTFNL3	A20-DTFNL3

Inserts

Toolholders

Boring Bars & Heads

Drills

Collet Chucks

Cartridges

Brazed Tools

Technical Data

Index

Technical Data

Cross Reference for Boring Bar Catalog Numbers (Cont'd)

Inserts

old cat. no.	new cat. no.
S20-DTFNR3	A20-DTFNR3
S20-DVUNL3	A20-DVUNL3
S20-DVUNR3	A20-DVUNR3
S20-KCLPL4	A20-CCLPL4
S20-KCLPR4	A20-CCLPR4
S20-KSKPR4	A20-CSKPR4
S20-KTFPL3	A20-CTFPL3
S20-KTFPR3	A20-CTFPR3
S20-NDLPL4	A20-NDLPL4
S20-NDLPR4	A20-NDLPR4
S20-NEL3	A20-NEL3
S20-NER3	A20-NER3
S20-NVLPL3	A20-NVLCL3
S20-NVLPR3	A20-NVLCR3

Toolholders

Boring Bars & Heads

Drills

Collet Chucks

Cartridges

Brazed Tools

Technical Data

Index

old cat. no.	new cat. no.
S24-KCLPL4	A24-CCLPL4
S24-KCLPR4	A24-CCLPR4
S24-KSKPR4	A24-CSKPR4
S24-KSKPR6	A24-CSKPR6
S24-KTFPL3	A24-CTFPL3
S24-KTFPL4	A24-CTFPL4
S24-KTFPR3	A24-CTFPR3
S24-KTFPR4	A24-CTFPR4
S24-NDLPL4	A24-NDLPL4
S24-NDLPR4	A24-NDLPR4
S24-NEL3	A24-NEL3
S24-NER3	A24-NER3
S24-NVLPL3	A24-NVLCL3
S24-NVLPR3	A24-NVLCR3

old cat. no.	new cat. no.
S32-DCFNL5	A32-DCFNL5
S32-DCFNL6	A32-DCFNL6
S32-DCFNR5	A32-DCFNR5
S32-DCFNR6	A32-DCFNR6
S32-DCKNL4	A32-DCKNL4
S32-DCKNL5	A32-DCKNL5
S32-DCKNR4	A32-DCKNR4
S32-DCKNR5	A32-DCKNR5
S32-DCLNL4	A32-DCLNL4
S32-DCLNL5	A32-DCLNL5
S32-DCLNL6	A32-DCLNL6
S32-DCLNR4	A32-DCLNR4
S32-DCLNR5	A32-DCLNR5
S32-DCLNR6	A32-DCLNR6
S32-DDUNL4	A32-DDUNL4
S32-DDUNR4	A32-DDUNR4
S32-DSKNL6	A32-DSKNL4
S32-DSKNR6	A32-DSKNR4
S32-DTFNL4	A32-DTFNL4
S32-DTFNR4	A32-DTFNR4
S32-DVUNL4	A32-DVUNL4
S32-DVUNR4	A32-DVUNR4
S32-KSKPR6	A32-CSKPR6
S32-KTFPL4	A32-CTFPL4
S32-KTFPR4	A32-CTFPR4
S32-NDLPL4	A32-NDLPL4
S32-NDLPR4	A32-NDLPR4
S32-NEL3	A32-NEL3
S32-NEL4	A32-NEL4
S32-NEL5	A32-NEL5
S32-NEL6	A32-NEL6
S32-NER3	A32-NER3
S32-NER4	A32-NER4
S32-NER5	A32-NER5
S32-NER6	A32-NER6
S32-NVLPL3	A32-NVLCL3

old cat. no.	new cat. no.
S32-NVLPR3	A32-NVLCR3
S36-DCLNL6	A36-DCLNL6
S36-DCLNR6	A36-DCLNR6
S36-DSKNL6	A36-DSKNL4
S36-DSKNR6	A36-DSKNR4
S36-DTFNL4	A36-DTFNL4
S36-DTFNR4	A36-DTFNR4
S36-NEL4	A36-NEL4
S36-NER4	A36-NER4

S40-DCFNL6	A40-DCFNL6
S40-DCFNR6	A40-DCFNR6
S40-DCKNL5	A40-DCKNL5
S40-DCKNL6	A40-DCKNL6
S40-DCKNR5	A40-DCKNR5
S40-DCKNR6	A40-DCKNR6
S40-DCLNL5	A40-DCLNL5
S40-DCLNL6	A40-DCLNL6
S40-DCLNR5	A40-DCLNR5
S40-DCLNR6	A40-DCLNR6
S40-DTFNL4	A40-DTFNL4
S40-DSKNL6	A40-DSKNL4
S40-DSKNR6	A40-DSKNR4
S40-DTFNL4	A40-DTFNL4
S40-DTFNR4	A40-DTFNR4
S40-DVUNL4	A40-DVUNL4
S40-DVUNR4	A40-DVUNR4
S40-KSKPR6	A40-CSKPR6
S40-KTFPL4	A40-CTFPL4
S40-KTFPR4	A40-CTFPR4
S40-NEL3	A40-NEL3
S40-NEL4	A40-NEL4
S40-NEL5	A40-NEL5
S40-NEL6	A40-NEL6
S40-NER3	A40-NER3
S40-NER4	A40-NER4
S40-NER5	A40-NER5
S40-NER6	A40-NER6

Weights for Boring Bars

catalog number	diameter	overall length	bar weight (lbs.)	head weight (lbs.)	total weight (lbs.)
B-6422-1	2.750	35.00	89.7	3.2	92.9
B-6424-1	3.000	38.00	116.5	3.7	120.2
B-6428-1	3.500	44.00	199.9	4	203.9
B-6432-1	4.000	50.00	277.5	8	285.5
B-6436-1	4.500	56.00	397.3	10.5	407.8
B-6440-1	5.000	63.00	471.4	13.8	485.2
B-6448-1	6.000	75.00	956.7	19.9	976.6

catalog number	diameter	length	weight (lbs.)
B-7908	1	12	4.4
B10-CTFPR2	0.625	8	0.7
B10-SCLPL3	0.625	8	0.7
B10-SCLPR3	0.625	8	0.7
B12-CTFPR3	0.75	9	1.1
B12-SCLPL3	0.75	10	1.2
B12-SCLPR3	0.75	10	1.2
B14-CTFPR3	0.875	10	1.7
B16-CTFPR3	1	11	2.5
B16-SCLPL3	1	12	2.7
B16-SCLPR3	1	12	2.7
B20-CTFPR3	1.25	13	4.7
B24-CTFPR4	1.5	15.5	8.1
B28-CTFPR4	1.75	18.5	13
B32-CTFPR4	2	21.5	20.3
B40-CTFPR4	2.5	27.5	40
BL-7908	1	12	4.4
C-11816W	1	11	4.2
C-11820W	1.25	11	7
C-11924W	1.5	15	10.4
C-11928W	1.75	17	15.9
C-11932W	2	20	27
C-11936W	2.25	22	38.4
C-11940W	2.5	25	54.3
C-6420	1.25	11	6.3
C-6420W	1.25	11	6.6
C-6424W	1.5	14	11.9
C-6428W	1.75	16	19
C-6432W	2	19	30
C-6436W	2.25	21	42.5
C-6440W	2.5	24	59.2
C04-KBFPR03	0.25	3.94	0.1
C04-KBFPR05	0.25	3.94	0.1
C04-KBLPL03	0.25	3.94	0.1
C04-KBLPL05	0.25	3.94	0.1
C04-KBLPR03	0.25	3.94	0.1
C04-KBLPR05	0.25	3.94	0.1
C05-KBFPR05	0.312	4.92	0.2
C05-KBLPL05	0.312	4.92	0.2
C05-KBLPR05	0.312	4.92	0.2
C12-SCLPL3	0.75	10	2
C12-SCLPR3	0.75	10	2
C16-SCLPL3	1	12	4.4
C16-SCLPR3	1	12	4.4
D-5420W	1.25	10	3.1
D-5424W	1.5	12	5.4
D-5428W	1.75	14	9.1
D-5432W	2	16	13.5
D-5436W	2.25	18	19.7
D-5440W	2.5	20	27.8
E03-SCLDL1.2	0.188	4	0.1
E03-SCLDR1.2	0.188	4	0.1
E03-SWLPL1.5	0.188	4	0.1
E03-SWLPR1.5	0.188	4	0.1

catalog number	diameter	length	weight (lbs.)
E04-SCLDL1.2	0.25	4	0.1
E04-SCLDR1.2	0.25	4	0.1
E04-SWLPL1.5	0.25	4	0.1
E04-SWLPR1.5	0.25	4	0.1
E05-SCLPL1.8	0.312	5	0.2
E05-SCLPR1.8	0.312	5	0.2
E05-STFPL1.8	0.312	5	0.2
E05-STFPR1.8	0.312	5	0.2
E05-SWLPL1.5	0.312	5	0.2
E05-SWLPR1.5	0.312	5	0.2
E06-LSEL2	0.375	6	0.3
E06-LSER2	0.375	6	0.3
E06-SCLPL2	0.375	6	0.3
E06-SCLPR2	0.375	6	0.3
E06-SDUPL2	0.375	6	0.3
E06-SDUPR2	0.375	6	0.3
E06-STFPL2	0.375	6	0.3
E06-STFPR2	0.375	6	0.3
E06-STLPL2	0.375	6	0.3
E06-STLPR2	0.375	6	0.3
E06-STUNL2	0.375	6	0.3
E06-STUNR2	0.375	6	0.3
E06-SWLPL2	0.375	6	0.3
E06-SWLPR2	0.375	6	0.3
E06A-STFPL2A	0.375	4	0.2
E06A-STFPR2A	0.375	4	0.2
E06D-STFPL2A	0.375	6	0.3
E06D-STFPR2A	0.375	6	0.3
E08-CTFNL2	0.5	8	0.7
E08-CTFNR2	0.5	8	0.7
E08-CTLNL2	0.5	8	0.7
E08-CTLNR2	0.5	8	0.7
E08-LSEL2	0.5	8	0.7
E08-LSER2	0.5	8	0.7
E08-NEL2	0.5	8	0.7
E08-NER2	0.5	8	0.7
E08-NKLCL05	0.5	8	0.7
E08-NKLCR05	0.5	8	0.7
E08-SCLPL2	0.5	8	0.7
E08-SCLPR2	0.5	8	0.7
E08-SDUPL2	0.5	8	0.7
E08-SDUPR2	0.5	8	0.7
E08-STFPL2	0.5	8	0.7
E08-STFPR2	0.5	8	0.7
E08-STLPL2	0.5	8	0.7
E08-STLPR2	0.5	8	0.7
E08-STUNL2	0.5	8	0.7
E08-STUNR2	0.5	8	0.7
E08-SWLPL2	0.5	8	0.7
E08-SWLPR2	0.5	8	0.7
E08C-CTFPL2	0.5	5	0.4
E08C-CTFPR2	0.5	5	0.4
E08F-CTFPL2	0.5	8	0.7
E08F-CTFPR2	0.5	8	0.7
E10-CCFNL3	0.625	10	1.4
E10-CCFNR3	0.625	10	1.4
E10-CCKNL3	0.625	10	1.4
E10-CCKNR3	0.625	10	1.4
E10-CCLNL3	0.625	10	1.4
E10-CCLNR3	0.625	10	1.4
E10-CRGNL3	0.625	10	1.4
E10-CRGNR3	0.625	10	1.4
E10-CSKNL3	0.625	10	1.4
E10-CSKNR3	0.625	10	1.4
E10-CTFNL2	0.625	10	1.4
E10-CTFNR2	0.625	10	1.4
E10-CTLNL2	0.625	10	1.4
E10-CTLNR2	0.625	10	1.4
E10-LSEL3	0.625	10	1.4

Inserts

Toolholders

Boring Bars & Heads

Drills

Collet Chucks

Cartridges

Brazed Tools

Technical Data

Index